

Luftreiniger-befeuchter / Air purifier-humidifier / Purificateur-humidificateur d'air / Purificatore-umidificatore d'aria

Defensor PH14

Bedienungsanleitung Operating instructions Instructions de service Istruzioni per l'uso



1109948 D/E/F/I 0406

Defensor®

Deutsch	Aufbau, Funktion, Standort	3
	Installation	4
	Bedienung	5
	Wartung	6
	Technische Daten	9
	Was ist, wenn?	10
	Schaltuhr einstellen/Ionisation (PH14plus)	11
	Ersatzteile	51
English	Design, function, location	15
	Installation	16
	Appliance operation	17
	Maintenance	18
	Technical data	21
	What if?	22
	Setting the timer/ionisation (PH14plus)	23
	Spare parts	51
Français	Constitution, fonctionnement, implantation	27
	Installation	28
	Manipulation	29
	Maintenance	30
	Données techniques	33
	Que faire si?	34
	Horloge de commutation/ionisation (PH14plus)	35
	Pièces de rechange	51
Italiano	Costruzione, funzione, ubicazione	39
	Installazione	40
	Uso	41
	Manutenzione	42
	Dati tecnici	45
	Cosa fare, se?	46
	Regolazione del timer/ionizzazione (PH14plus)	47
	Ricambi	51

Aufbau, Funktion, Standort

Aufbau

- 1 Ansauggitter
- 2 Grobfilter
- 3 Ventilator
- 4 Kreisel (Zentrifuge)
- 5 Luftwaschkammer
- 6 Verdunstermatte beflocht oder Aktivkohle-Verdunstermatte
- 7 Tropfenabscheider
- 8 Grobstaubfilter oder Quattrofilter
- 9 Wassertanks
- 10 Fahrgestell (mit Wasserwanne PH14A)
- 11 Wasserwagen

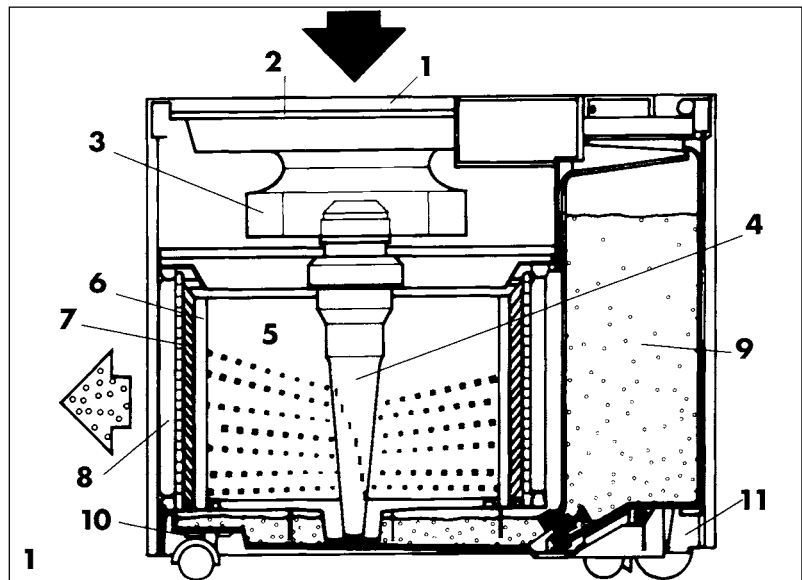

Funktion

Das Gerät misst laufend die Feuchtigkeit in Ihrem Raum (Istwert) und vergleicht sie mit dem eingestellten Wert (Sollwert).

Der angezeigte Istwert kann vom Sollwert abweichen. Wenn der Sollwert längere Zeit unterschritten wird, muss das Gerät in die nächsthöhere Stufe geschaltet werden.

Wollen sie das Gerät längere Zeit ausschliesslich zur Luftreinigung einsetzen, dann entleeren Sie die Wassertanks bzw. schliessen Sie den Hahn in der Wasserzuführung (PH14A).

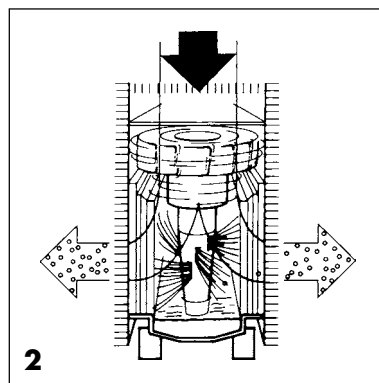

Wenn der Istwert (z.B. 40) kleiner ist als der Sollwert (z.B. 45), befeuchtet das Gerät die Raumluft und reinigt sie gleichzeitig.

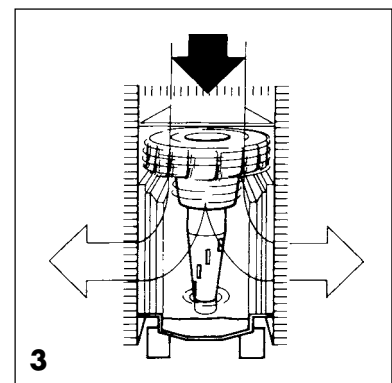

Wenn der eingestellte Sollwert (z.B. 45) erreicht ist, reinigt das Gerät die Raumluft, ohne sie zu befeuchten.

Standort wählen

Bild 4 Optimale Umwälzung der Raumluft erreichen Sie, wenn Sie das Gerät nicht direkt an eine Wand stellen. Stellen Sie das Gerät auf eine ebene Fläche, möglichst freistehend und gut zugänglich.

Stellen Sie das Gerät nicht hinter Vorhänge, dies beeinträchtigt die Luftzirkulation.

Wenn Sie das Gerät unter einen Tisch stellen, muss zwischen Tisch und Gerät mind. ein Abstand von 10 cm sein. Legen Sie keine Gegenstände auf das Gerät, dies hätte eine Leistungsverminderung zur Folge.

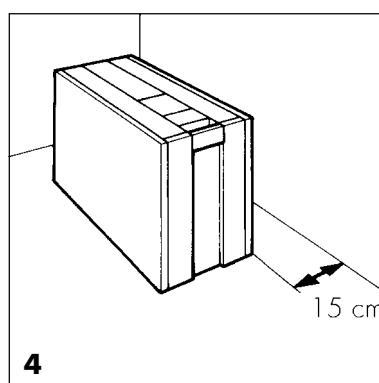

Vorsicht beim Verschieben des PH14. Gerät nicht anheben (Gefahr des Überschuppens von Wasser auf den Boden).

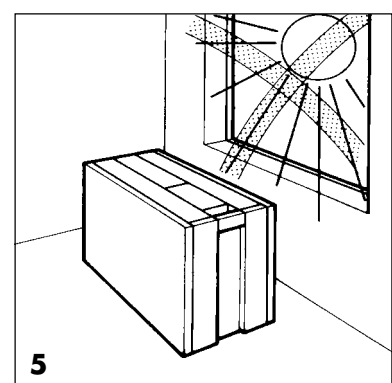

Dauernde direkte Sonnenbestrahlung schadet Ihrem Gerät.

Installation/Bedienung

Wasser anschliessen (PH14A)

Bild 1 Lassen Sie das Gerät durch einen Fachmann anschliessen (Anschlusswerte siehe technische Daten).

Kontrollieren Sie vor dem Einschalten ob der Hahn in der Wasserzuleitung offen ist.

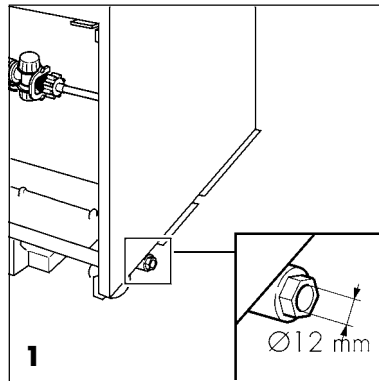

Netzspannung kontrollieren

Bild 2 Kontrollieren Sie, ob das Geräteschild die richtige Netzspannung angibt.

Achtung! Schliessen Sie das Gerät nicht an, falls diese Angabe nicht mit der Netzspannung in Ihrem Land übereinstimmt!

Räder arretieren

Bild 3 Wenn das Gerät am gewünschten Ort steht, arretieren Sie die Räder.

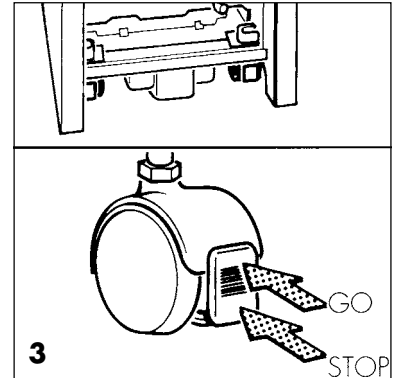
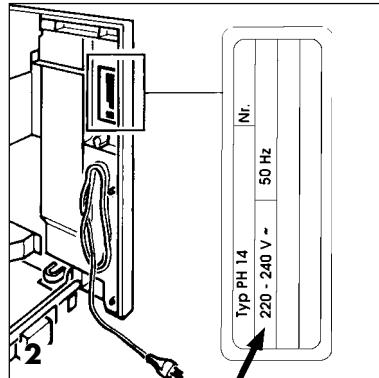

Wasser auffüllen (PH14)

Bild 4-7 Wenn die Sollwert-Anzeige blinkt und die Lampe "Wassermangel" leuchtet, sind die Kanister leer.

Bevor Sie den Wasserwagen wegfahren, sollten Sie ein Tuch auf den Boden legen, damit kein Wasser auf den Boden tropft.

Heben Sie dann den Griff hoch und fahren Sie den Wagen weg oder legen Sie den Wagen auf den Boden und entnehmen Sie die Kanister einzeln.

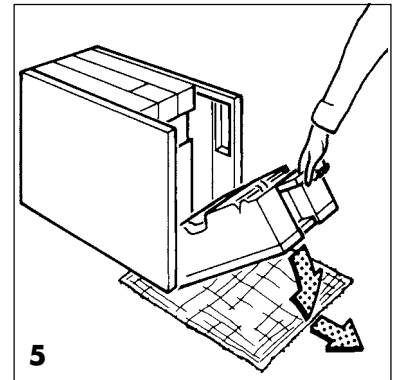
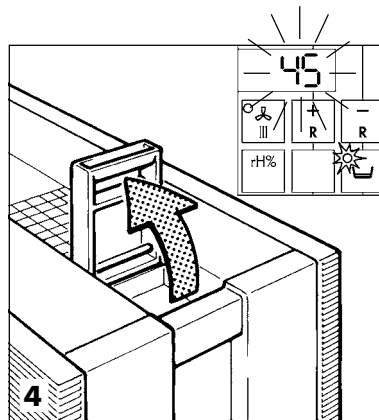

Füllen Sie die Kanister mit Leitungswasser auf.

Achtung! Wasserzusätze können die Reinigungskraft der Aktivkohle-Verdunstermatte beeinträchtigen.

Verwenden Sie nur Wasserzusätze, bei welchen Gesundheitsschäden – auch hinsichtlich Langzeitwirkung – ausgeschlossen sind. Achten Sie auf Unbedenklichkeitsbescheinigung.

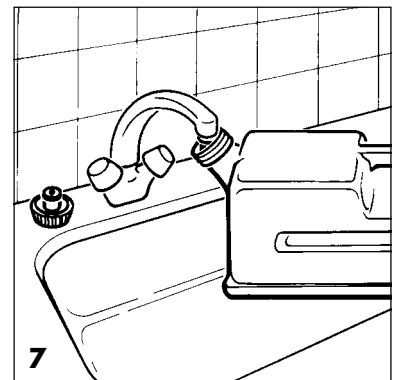
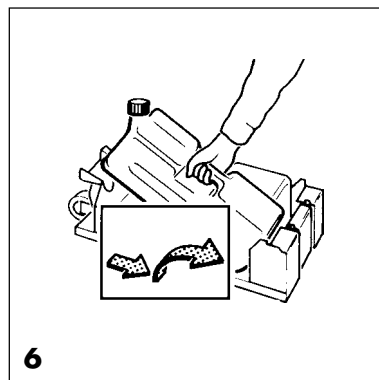

Bedienung

Gerät einschalten

- Drücken Sie die **Ein/Aus**-Taste. Wählen Sie dann entsprechend Ihren Raumverhältnissen die Ventilatorstufe I, II oder III (siehe technische Daten, Seite 9).
- Drücken Sie bei der **ersten Inbetriebnahme** gleichzeitig während mind. 3 Sek die beiden R-Tasten (Reset-Funktion: siehe Seite 14).

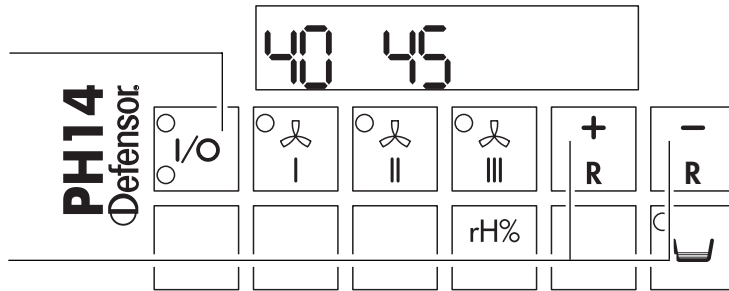

Betriebsart wählen

- **Reinigen und Befeuchten**
Ab Werk oder nach einem Reset (siehe Seite 14) arbeitet das Gerät in der Betriebsart **„Reinigen und Befeuchten“**: Der Kreisel stellt nach Erreichen der Sollfeuchte ab und der Ventilator läuft weiter.
- **Nur Befeuchten**
Durch gleichzeitiges Drücken (mind. 3 Sek.) der Ventilator-Tasten „I“ und „II“ schalten Sie in die Betriebsart **„nur Befeuchten“** um: Nach Erreichen der Sollfeuchte stellen der Kreisel und der Ventilator gemeinsam ab. Alle 15 Minuten läuft der Ventilator für 5 Sekunden an, um einen Feuchtestau im Gerät zu verhindern.
Durch gleichzeitiges Drücken (mind. 3 Sek.) der Ventilator-Tasten „II“ und „III“ schalten Sie wieder in die Betriebsart **„Reinigen und Befeuchten“** zurück.

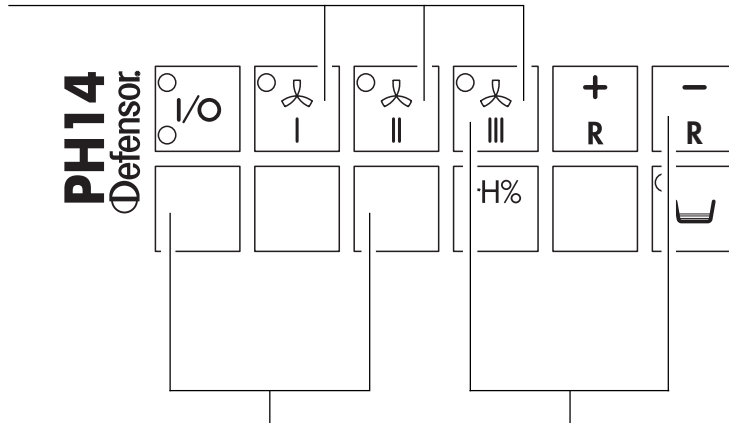

Wollen Sie die **Einstellung sichern?**

- Drücken Sie gleichzeitig während mind. 3 Sek. diese beiden Tasten. Jetzt sind alle Einstellungen gesichert, inkl. Ein/Aus. Entsichern Sie die Einstellung auf die gleiche Weise.

Bei Verwendung des PH14 als Luftreiniger ohne Wasser blinkt die Wassermangel-Anzeige.

- Durch gleichzeitiges Drücken dieser beiden Tasten während mind. 3 Sek. können Sie die **Wassermangel-Anzeige ausschalten**. Sobald Sie wieder Wasser auffüllen, ist die Anzeige wieder betriebsbereit.

Raumluftfeuchtigkeit (Istwert) ablesen

- Drücken Sie die rH%-Taste.

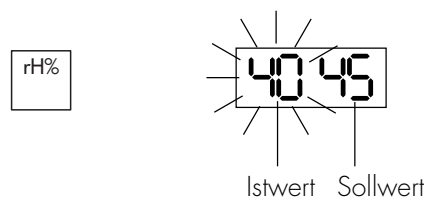

Sollwert einstellen

Für Wohnräume empfehlen wir eine relative Luftfeuchtigkeit von 45%.

- Drücken Sie die Plus-Taste oder die Minus-Taste, um den eingestellten Wert zu erhöhen oder zu vermindern.

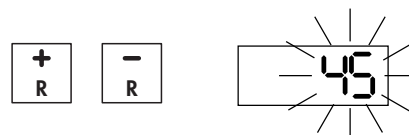

Nach längerem Stillstand des Gerätes kann die genaue Raumluftfeuchtigkeit erst nach ca. 30 Min. abgelesen werden. Beim Wegfahren des Wasserwagens schaltet die Anzeige aus. Nach dem Wiedereinschalten kann die genaue Raumluftfeuchtigkeit erst nach ca. 1 Min. abgelesen werden.

Wartung

Ihr Gerät erbringt die volle Befeuchtungs- und Reinigungsleistung nur, wenn es regelmäßig gereinigt wird und Verschleiss-teile ersetzt werden. Reinigen Sie die Geräte-Aussenseite nur mit feuchtem Tuch ohne scheuernde oder ätzende Mittel. Die Reinigungsintervalle hängen stark vom Einsatzort ab: Bei stark verschmutzter Raumluft müssen die Filter öfters gewechselt werden. Bei sehr hartem Wasser müssen die nassen Teile öfters gereinigt werden.

- Diese Teile **reinigen**:

Grobfilter – Grobstaubfilter oder Quattrofilter – Fahrgestell – Zwischenboden – Wasserwanne – Tropfenabscheider – Verdunstermatte, beflockt oder Aktivkohle-Verdunstermatte

- Diese Teile **auswechseln**:

Grobfilter – Grobstaubfilter oder Quattrofilter – Verdunstermatte, beflockt oder Aktivkohle-Verdunstermatte

Achtung! Vor allen Wartungsarbeiten ist das Gerät vom Stromnetz zu trennen!

Bild 1 Ziehen Sie zuerst den Netzstecker aus und legen Sie ein Tuch auf den Boden unter den Wasserwagen.

Wasserwagen entfernen.

Bild 2 Beide Verriegelungen unten am Gerät nach innen drücken. Bleibt das Gerät am Ort, so können die Verriegelungen offen bleiben (Sie dienen nur als Transportsicherung).

Bild 3 Gehäuse abheben.











Bild 4 Grobstaubfilter oder Quattrofilter und Zwischenboden abheben. Achten Sie darauf, dass der Grobstaubfilter oder Quattrofilter nicht nass wird.

Bild 5 PH14A: Wasserwanne mit mitgelieferter Pumpe entleeren.

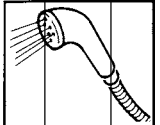
Bild 6 Beide Halter abheben.

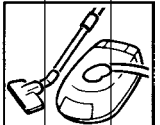
Verdunstermatte zusammendrücken und herausziehen.

Monat

1	2	3	4	5	6	7	8	9	10	11	12
	  										
 											
					 						

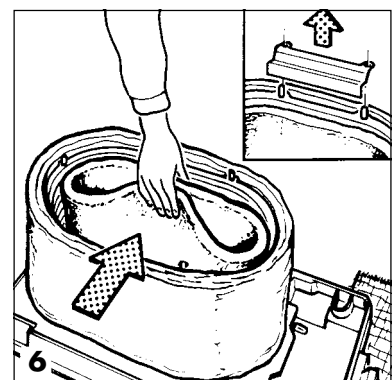
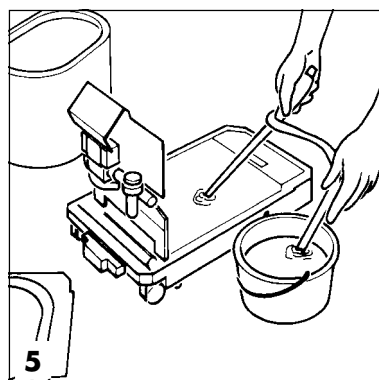
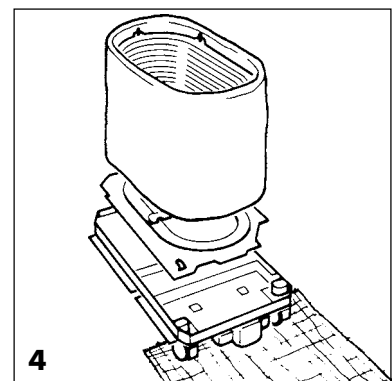
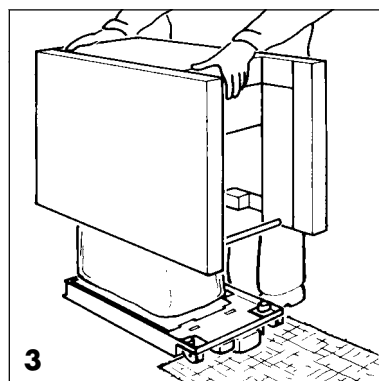
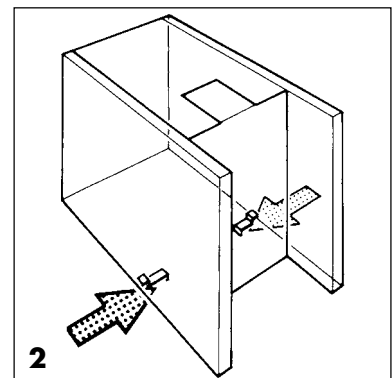
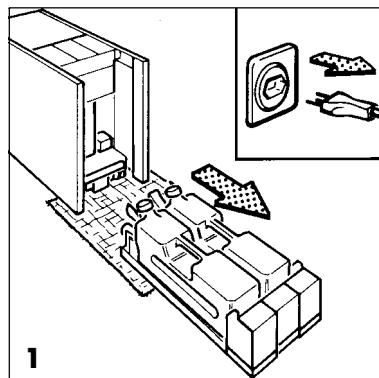

Wartung

Bild 1 Grobstaubfilter oder Quattrofilter abziehen.

Bei schwacher Verschmutzung mit Staubsauger reinigen.

Bei starker Verschmutzung auswechseln.

Bild 2 Kippen Sie das Gehäuse.



Bild 3 Ziehen Sie den Kreisel gerade aus der Kupplung heraus.

Reinigen Sie den Schwimmerschalter. (PH14A: zusätzlich Sicherheitsschalter)

Bild 4 Reinigen Sie den Kreisel mit der mitgelieferten Bürste.

Achten Sie beim Einsetzen des Kreisels darauf, dass er gut einrastet (sonst können Vibrationen auftreten).

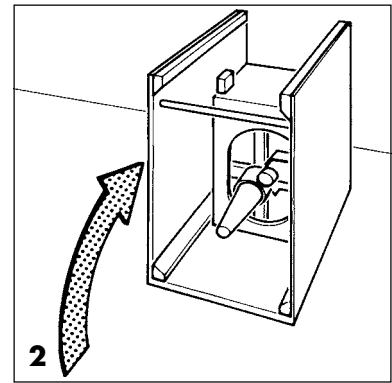
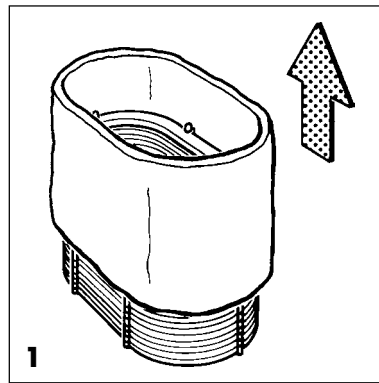

Bild 5 PH14: Verdunstermatte, Tropfenabscheider, Zwischenboden und Fahrgestell reinigen.

Bild 6 PH14A: zusätzlich Wasserwanne reinigen.

Reinigen Sie die Verdunstermatte ausschließlich mit lauwarmem Wasser ohne Reinigungsmittel.

Reinigen Sie von Zeit zu Zeit die anderen Teile (Bild 5 und 6) mit Entkalkungsmittel oder Essig.

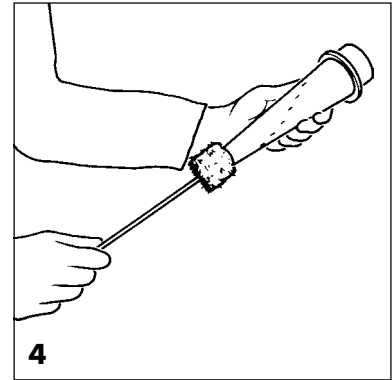
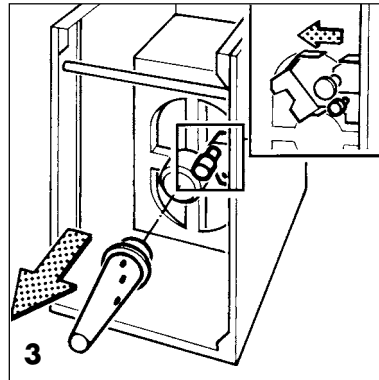

Bild 7 Reinigen Sie den Grobfilter mit dem Staubsauger, wenn er schwach verschmutzt ist.

Bild 8 Ersetzen Sie ihn, wenn er stark verschmutzt ist.

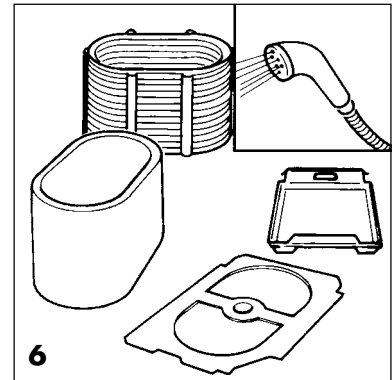
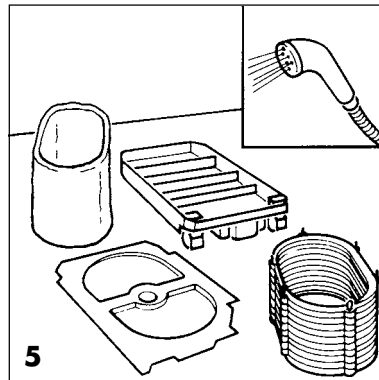
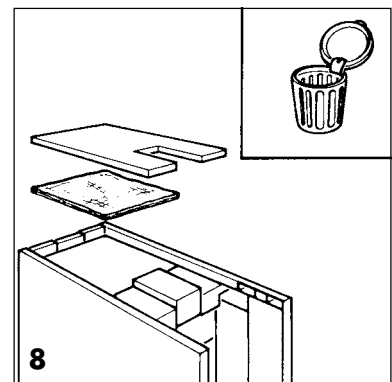
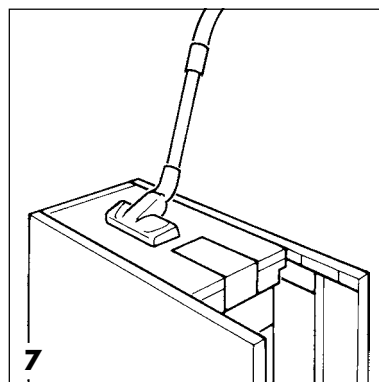

Wartung

Bild 1 PH14A: Schrauben Sie die untere Verschlusskappe des Siebfilters ab und spülen Sie den Siebfiltereinsatz mit warmem Leitungswasser aus.



Bild 2 Achten Sie beim Montieren des Gehäuses darauf, dass die Niveauschalterabdeckung am Quattrofilter vorbeigleitet.



Bild 3 Die Querstange muss genau in die Aussparung gesetzt werden.

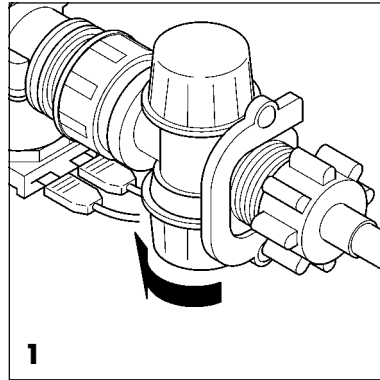

Achtung! Bei längerem Nichtbetrieb und nach dem Entkalken, Gerät immer gut ausspülen!

Zusätzliche Wartung beim PH14(A)plus

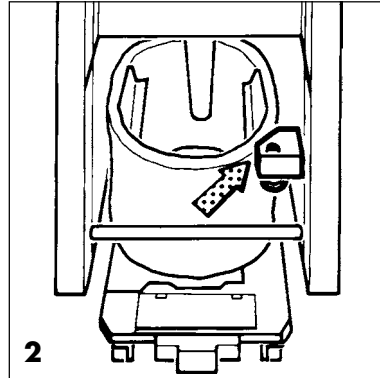
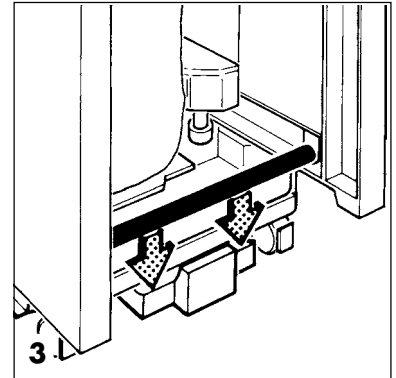
Reinigen Sie die Ionisierungs-Nadel bei jeder Wartung des Gerätes mit einem Tuch.

Nach etwa einem Jahr sollte die Ionisierungs-Nadel ersetzt werden. Mit einer kleinen Pinzette kann die alte Ionisierungs-Nadel gerade herausgezogen, bzw. die neue wieder hineingedrückt werden.

Technische Daten

Masse (BxHxT)	cm	73 x 61 x 37		
Gewicht (ohne Wasser)	kg	25		
Inhalt Wassertanks	l	2 x 10		
Umgebungstemperatur	°C	5 – 50		
Umgebungsfeuchtigkeit	% r.F.	0 – 85		
Leistungsstufen		I	II	III
Luftumwälzung	m ³ /h	180	280	360
Befeuchtungsleistung (bei 23 °C/45% r.F.)	l/h	0.6	0.9	1.2
Schall-Leistungspegel (DIN45635)	dB(A)	41	49	56
Filterfläche	m ²	0.4		
Wirkungsgrad gegen atmosphärischen Staub	%	82		
Abscheidegrad Quattrofilter gegen synthetischen Staub	%	>99		
Netzspannung	V ~	100... 120/220... 240		
Netzfrequenz	Hz	50/60		
Leistungsaufnahme	W	max. 55		
Prüfzeichen		SEV, VDE, GS, CE		
PH14A:				
Wasseranschluss (Aussen-Ø)	mm	12		
Wassernetzdruck	bar	0.5 – 6		
Wasserzulauftemperatur	°C	5 – 40		
PH14(A)plus:				
Negativionen	Neg. Ionen/cm ³	300 – 600'000		
Ausgangsspannung	kV (negativ)	6.5		
Luftionisator				

Maximale Raumgrösse

Leistungsstufe	Raumgrösse für Luftbefeuchtung (bei 2.5 g/h · m ³ Feuchtebedarf)	Raumgrösse für Luftreinigung bei 1 – 4-facher Luftumwälzung pro Stunde
I	max. 180 m ³	max. 45 m ³ bis 180 m ³
II	max. 280 m ³	max. 70 m ³ bis 280 m ³
III	max. 360 m ³	max. 90 m ³ bis 360 m ³
Beispiel 1:	Sie wollen in einem Raum von 80 m ² Grundfläche und 2.5 m Höhe die Luft befeuchten: 80 m ² x 2.5 m = 200 m ³ Die Luft in diesem Raum kann mit dem PH14 je nach natürlicher Luftfeuchtigkeit auf Stufe I bis II befeuchtet werden.	
Beispiel 2:	Sie wollen in einem Raum von 110 m ² Grundfläche und 3.2 m Höhe die Luft reinigen: 110 m ² x 3.2 m = 352 m ³ Die Luft in diesem Raum kann mit dem PH14 auf Stufe III einmal pro Stunde umgewälzt werden.	

Was ist, wenn?

Störung	Ursache	Behebung
 Nur PH14A: Rote Lampe bei I/O-Taste leuchtet, Anzeige "Help" blinkt	Wasserspiegel in Wanne ist zu hoch	<ul style="list-style-type: none"> • Wasserwanne mit Pumpe entleeren • Sicherheitsschalter reinigen oder ersetzen • evtl. Defensor-Vertretung rufen
 Gelbe Lampe leuchtet und Sollwert blinkt	Kein Wasser im Fahrgestell, bzw. in der Wasserwanne	PH14: <ul style="list-style-type: none"> • Wassertanks nachfüllen • Wasserzufuhr überprüfen • Schwimmerschalter reinigen PH14A: <ul style="list-style-type: none"> • Siebfiltereinsatz reinigen und/oder einsetzen • Schwimmerschalter reinigen • Defensor-Vertretung rufen
Raumluft erreicht die eingestellte Luftfeuchtigkeit (Sollwert) nicht	<ul style="list-style-type: none"> – Fehlende Verdunstermatte – Hohe Raumtemperatur – Gerät stark verschmutzt – Offene Türen oder Fenster – Häufiges, langes Lüften des Raumes (also ständiger Austausch der feuchten Raumluft gegen trockene Aussenluft) – Raum zu gross 	<ul style="list-style-type: none"> • Neue Verdunstermatte einlegen • Reduzieren Sie die Raumtemperatur auf 20 – 22 °C • Wartung durchführen (siehe Seiten 6 – 8) • Türen und Fenster schliessen • Nur kurz lüften! • Sie benötigen mehr als ein Gerät
Anzeigen leuchten nicht	Griff nicht richtig eingerastet Netzstecker ausgezogen	<ul style="list-style-type: none"> • Griff einrasten • Netzanschluss prüfen • Netzsicherung des Raumes prüfen
Der Sollwert wird deutlich überschritten	Natürliche Luftfeuchtigkeit ist höher als eingestellte Luftfeuchtigkeit (Sollwert)	Für die Reinigung der Raumluft können Sie Ihr Gerät einfach weiter laufen lassen
Nach dem Auffüllen der Wassertanks oder nach dem Ausziehen des Netzstecker oder nach Stromunterbruch schaltet das Gerät nicht auf die vorher eingestellte Ventilatorstufe	Stützbatterie ist erschöpft	Bei Defensor-Vertretung die Batterie ersetzen lassen

Garantie: Ihr PH14 Luftreiniger-befeuchter wurde vor Verlassen des Produktionswerkes einer sorgfältigen Prüfung unterzogen.

Die Garantiedauer beträgt 1 Jahr ab Rechnungsdatum. Während dieser Zeit werden alle durch Material- oder Fabrikationsfehler schadhaften Teile gratis ersetzt.

Von der Garantie ausgeschlossen sind:

- Schäden, die durch unsachgemässe Behandlung oder Eingriffe entstehen.
- Verschleissteile, die durch ihre Funktion einer natürlichen Abnutzung ausgesetzt sind.

Verwenden Sie für eine allfällige Rücksendung des schadhaften Gerätes die Originalverpackung. Sie bietet einen optimalen Transportschutz.

Achtung! Das Netzanschlusskabel darf nur vom Elektro-Fachhändler oder vom autorisierten Defensor-Vertreter ausgewechselt werden.

Schaltuhr einstellen/Ionisation

Ionisierung einschalten

Durch Einschalten des Negativ-Ionen-Generators wird die Raumluft auch von den kleinsten gesundheitsgefährdenden Staubteilchen, wie Tabakrauch und Russ, freigehalten.

Negative Ionen ziehen schwebende Staubteilchen an und verbinden sich mit weiteren Staubteilchen zu sogenannten Clustern, die dank ihrer Grösse vom Luftfilter wirksam zurückgehalten werden. Die Ionisation der Luft verringert ausserdem elektrostatische Aufladungen.



Achtung! Der grösste Teil, der dank eingeschalteter Ionisierung gebildeten Staubcluster, wird im Luftfilter zurückgehalten. Es ist jedoch möglich, insbesondere bei erhöhter Schadstoffbelastung, dass sich ein geringer Teil der Staubcluster an Wänden und anderen Flächen im Raum niederschlägt. Stellen Sie Ihren PH1 4plus nicht in die unmittelbare Nähe einer Wand oder eines Vorhanges. Für allfällige Verschmutzung von Oberflächen übernehmen wir keine Verantwortung.

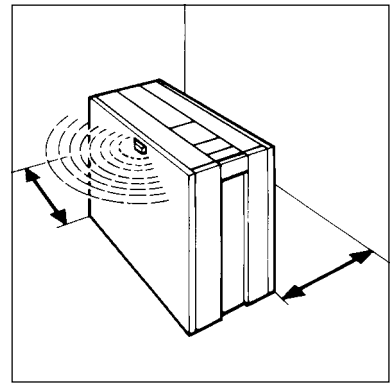

Schaltuhr einstellen:

Uhrzeit kontrollieren

- Drücken Sie die "Set"-Taste

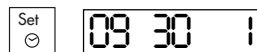

Jetzt erscheint die eingestellte Zeit und der eingestellte Wochentag (Montag = 1 ... Sonntag = 7)

Uhrzeit einstellen

- Drücken Sie gleichzeitig die "Set"-Taste und die "rH%"-Taste



Jetzt können Sie die Uhrzeit und den Wochentag verstellen.

Beispiel:

Ihr Gerät zeigt 9 Uhr 30, Montag (= 1)
Es ist jedoch 14 Uhr 10, Mittwoch (= 3)

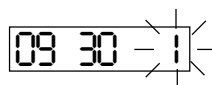

Stellen Sie als erstes den Wochentag ein.

- Drücken Sie die "+"-Taste bis "3" erscheint.

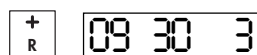

- Drücken Sie die "Set"-Taste und stellen Sie die Stunden ein.

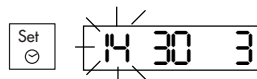

- Drücken Sie die "Set"-Taste und stellen Sie die Minuten ein.

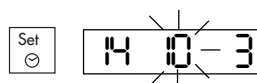

- Drücken Sie nochmals die "Set"-Taste.



Nach ca. 10 Sek. zeigt Ihr Gerät wieder den Sollwert der Raumluftfeuchtigkeit.

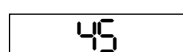

Schaltuhr einstellen

Funktion

Für jeden Wochentag stehen maximal 4 Schaltzeiten zur Verfügung.

Für jede Schaltzeit können folgende Einstellungen gemacht werden.

- Wochentag (1-7 = Mo-So)
- Stunde (0-24)
- Minute (0-60)
- Ventilatorstufe (I/II/III)
- Keine Ventilatorstufe (Ausschalten)

Die Einstellungen bestimmen immer den Betriebszustand bis zur nächsten Schaltzeit.

Im Beispiel schaltet das Gerät am Dienstag um 13 Uhr auf Stufe I. Das Gerät läuft auch am folgenden Tag noch auf dieser Stufe und erst die erste Schaltzeit des Mittwochs um 12 Uhr schaltet das Gerät dann auf Stufe 3.

Beispiel:

Montag

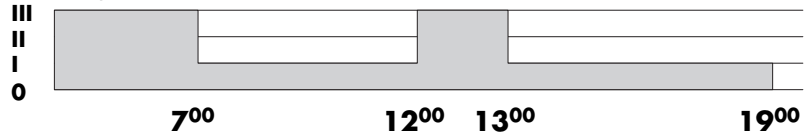

Dienstag

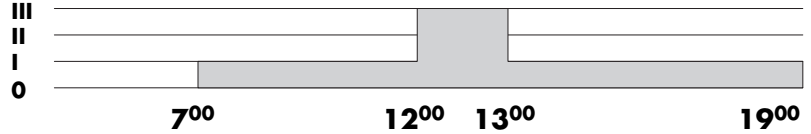

Mittwoch

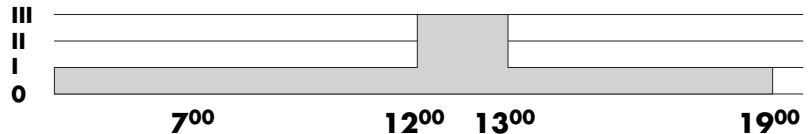

Donnerstag

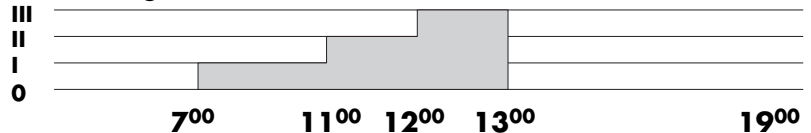

Freitag

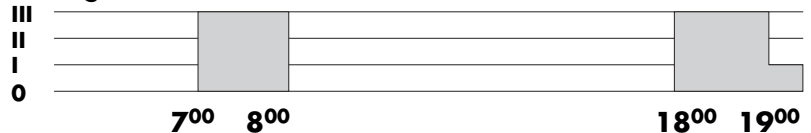

Samstag

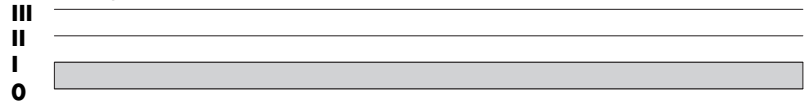

Sonntag

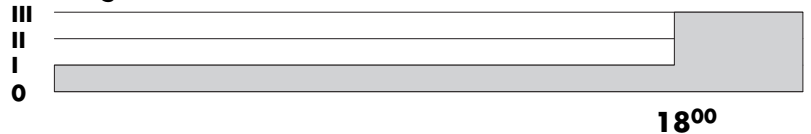

Stellen Sie die Schaltzeiten für Dienstag und Mittwoch ein (siehe Beispiel).

Gehen Sie so vor:

- Drücken Sie während 3 Sek. die Taste "P". Die Tagesanzeige blinkt. Jetzt können Sie die Schaltzeiten einstellen.
- Stellen Sie mit den "+/-"-Tasten den Tag ein (im Beispiel: Dienstag = 2).
- Drücken Sie "Set" und stellen Sie die Stunden ein (im Beispiel: 07).
- Drücken Sie "Set" und stellen Sie die Minuten ein (im Beispiel: 00).
- Drücken Sie "Set" und wählen Sie die Ventilatorstufe. Drücken Sie dazu auf die entsprechende Ventilator-Taste (im Beispiel Stufe I).

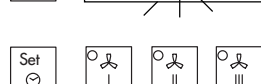
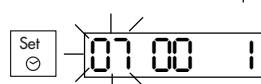
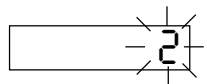
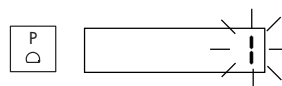

Schaltuhr einstellen

- Drücken Sie "Set", jetzt können Sie die weiteren Schaltzeiten des Dienstages einstellen.



2. Schaltzeit Dienstag

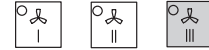
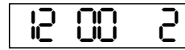

3. Schaltzeit Dienstag

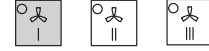
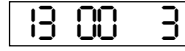

Da Sie keine 4. Schaltzeit benötigen, drücken Sie einfach mehrmals "Set", bis wieder die Uhrzeit angezeigt wird. Nach 10 Sek. erscheint dann der Sollwert der Luftfeuchtigkeit. Damit haben Sie alle Schaltzeiten für Dienstag eingestellt.



Stellen Sie nun die Schaltzeiten für Mittwoch ein. Drücken Sie wieder 3 Sek. lang die "P"-Taste und stellen Sie "3" für den Wochentag ein. Gehen Sie dann gleich vor wie bisher:

1. Schaltzeit Mittwoch

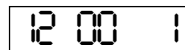

2. Schaltzeit Mittwoch

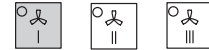

3. Schaltzeit Mittwoch

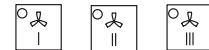
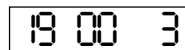

Damit das Gerät um 19 Uhr ausschaltet, wählen Sie keine Ventilatorstufe, sondern drücken Sie gleich "Set".

Drücken Sie wieder mehrmals "Set", bis die Uhrzeit, bzw. nach 10 Sek. die Luftfeuchtigkeit angezeigt wird. Jetzt haben Sie die Schaltzeiten für Mittwoch eingestellt.

Schaltzeiten abfragen

- Drücken Sie gleichzeitig die "P"- und die "Auto"-Taste.

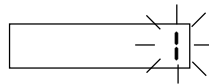

Die Tagesanzeige blinkt.

Wählen Sie mit den "+/-"-Tasten den Tag (im Beispiel: Dienstag = 2).

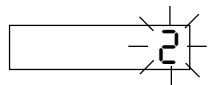

- Drücken Sie "Set".

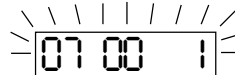

Sie sehen jetzt die erste (von vier) Schaltzeiten des gewählten Tages und die eingestellte Ventilatorstufe.



- Drücken Sie "Set" für die zweite, dritte und vierte Schaltzeit.



- Drücken Sie nochmals "Set".



Jetzt zeigt Ihr Gerät wieder die Uhrzeit und nach 10 Sek. den Sollwert der Raumluftfeuchtigkeit.

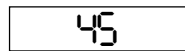

Wiederholen Sie die Abfrage für die anderen Wochentage.

Schaltuhr einstellen

Schaltautomatik Ein/Aus

Drücken Sie die "Auto"-Taste, um die Schaltuhr-Automatik ein- oder auszuschalten.

Wenn die Automatik in Betrieb ist, kann das Gerät weiterhin bedient werden wie sonst.

Die Ventilatorstufen können frei geändert werden und das Gerät kann auch ein- oder ausgeschaltet werden.

Es kann vorkommen, dass das Gerät nicht auf den Tastendruck reagiert, weil die Schaltuhr-Automatik gerade arbeitet. Versuchen Sie es nach ca. 2 Minuten nochmals.

Bei der nächsten Schaltzeit stellt dann die Schaltuhr-Automatik wieder den Wert ein, den Sie beim Einstellen der Schaltzeit bestimmt haben.

Reset

Durch Drücken der beiden "R"-Tasten können Sie alle Schaltzeiten und die Uhrzeit auf Null setzen. Gleichzeitig wird der Sollwert für die Luftfeuchtigkeit auf 45% gesetzt.

Bei einer allfälligen Fehlfunktion der Gerätesteuerung kann das Drücken der Reset-Tasten Abhilfe schaffen.

Die Reset-Funktion ist nicht in Betrieb, wenn Sie die Einstellungen gesichert haben (siehe "Einstellung sichern").

Einstellung sichern

Sie können die eingestellten Schaltzeiten gegen versehentliches Ändern sichern (siehe Seite 5).

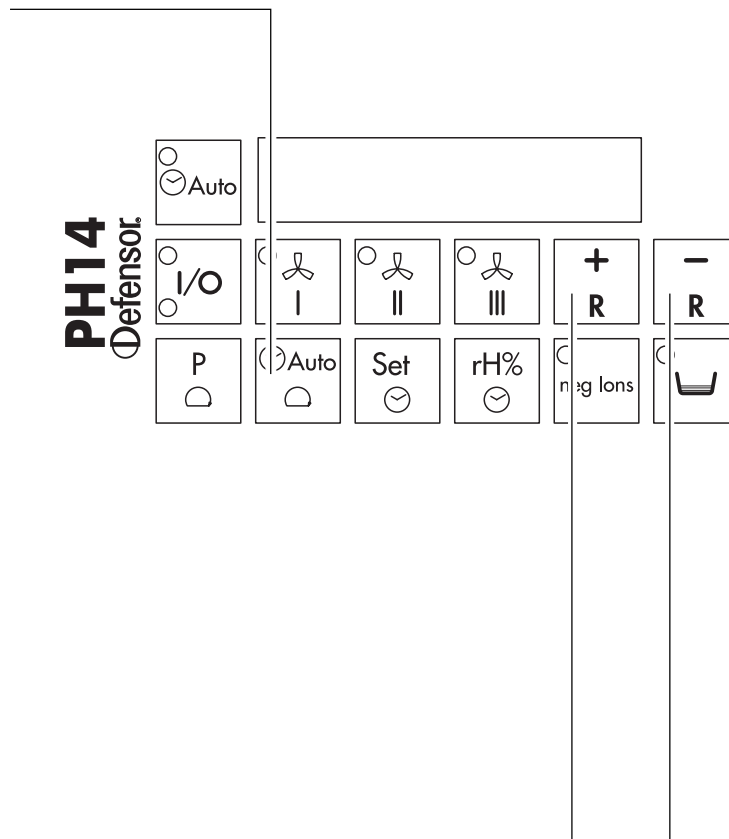

Design, function, location

Design

- 1 Intake grille
- 2 Coarse filter
- 3 Fan
- 4 Centrifuge
- 5 Air-scrubbing chamber
- 6 Flock-coated evaporator mat or activated carbon evaporator mat
- 7 Droplet trap
- 8 Coarse dust filter or Quattro filter
- 9 Water tanks
- 10 Mobile base (PH14A with humidifier basin)
- 11 Wheeled water carriage

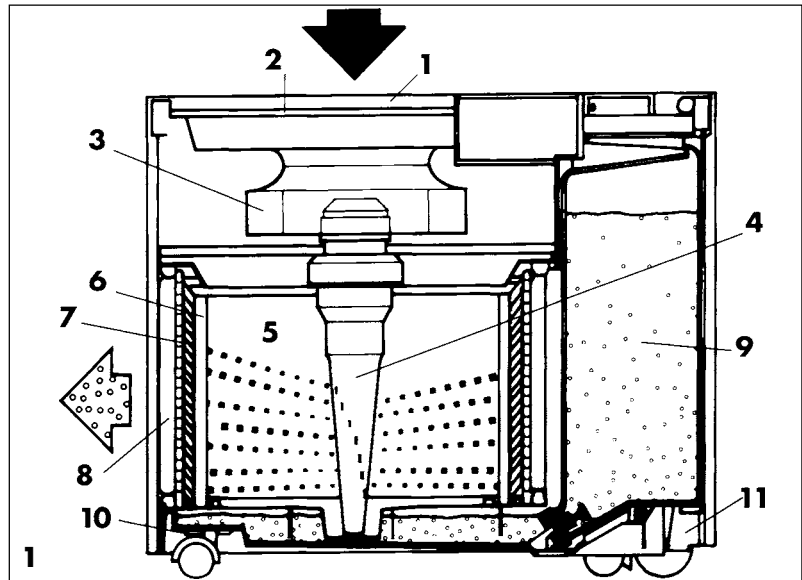

Function

The appliance continuously measures the actual humidity in your room (actual value) and compares it with the programmed setpoint (reference value).

The displayed actual value can deviate from the reference value. If it remains under the reference value for a prolonged period of time, the appliance must be switched to the next highest level.

If you wish to use the appliance solely for air purification purposes for a considerable period of time, empty the water tanks/close the valve in the water supply (PH14A).

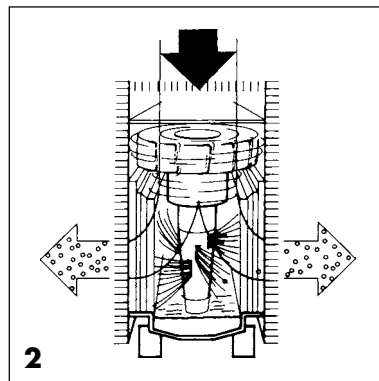

When the actual value (e.g. 40) is less than the reference value (e.g. 45), the appliance humidifies the room air and purifies it simultaneously.

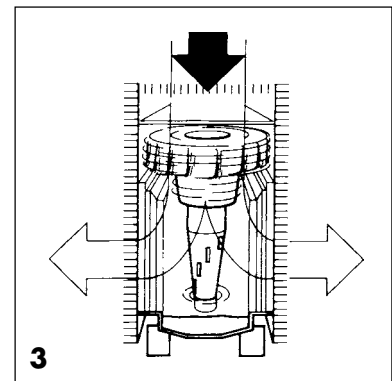

When the reference value (e.g. 45) is reached, the appliance purifies the room air without humidifying it.

Choose location

Fig. 4 To ensure optimized room-air circulation do not place the appliance directly against a wall. Place the appliance on a level surface, as freestanding and as readily accessible as possible.

Do not place the appliance behind curtains since this will adversely affect the air circulation.

If the appliance is placed under a table, there must be a clearance of at least 10 cm between the table and the appliance.

Do not place anything on the appliance since this would reduce its efficiency.

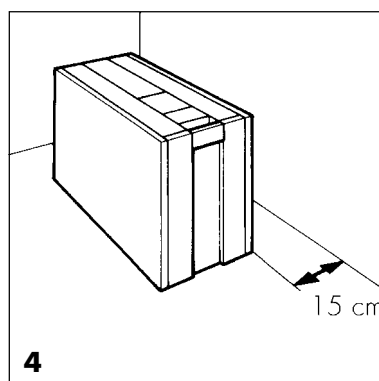

Move the PH14 carefully. Do not lift the appliance (to prevent spilling the water on the floor).

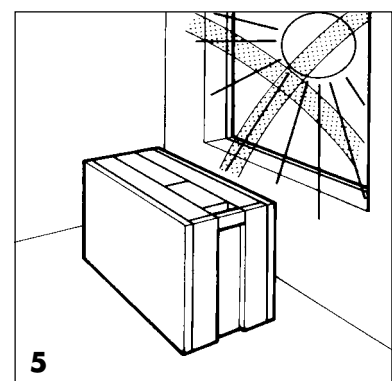

Continuous direct solar radiation is harmful for your appliance.

Installation/Appliance operation

Connection to water supply

(PH14A)

Fig. 1 Have the appliance connected to the water supply by a plumber (see technical data for connection values on page 21).

Check that the valve in the water supply is open.

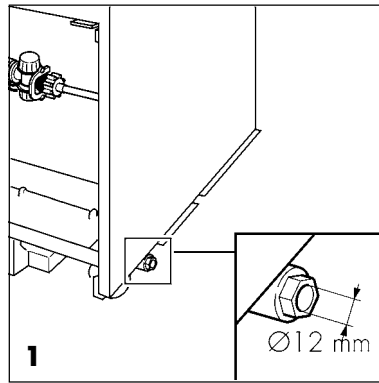

Check mains voltage

Fig. 2 Check that the rating plate displays the correct mains voltage.

Note: Do not connect the appliance if this voltage does not coincide with the voltage in your country.

Lock wheels

Fig. 3 Lock the wheels when the appliance is at the correct location.

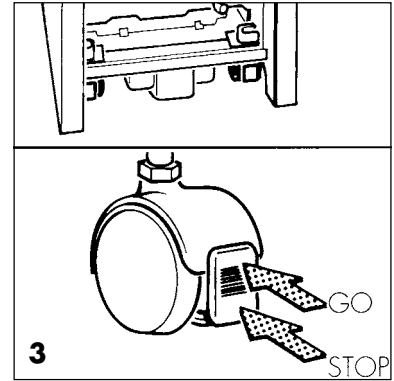
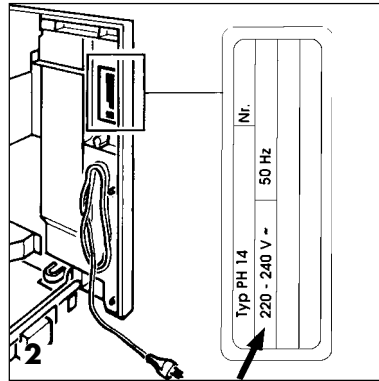

Fill with water (PH14)

Fig. 4-7 If the reference value indicator blinks and the "water low" lamp lights, the water tanks are empty.

Before you wheel the water carriage away, place a cloth on the floor to catch any water which might be spilled. Then lift up the handle and wheel the carriage away or lay it on the floor and remove the canisters one after the other.

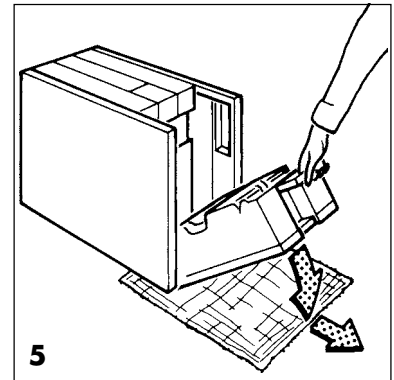
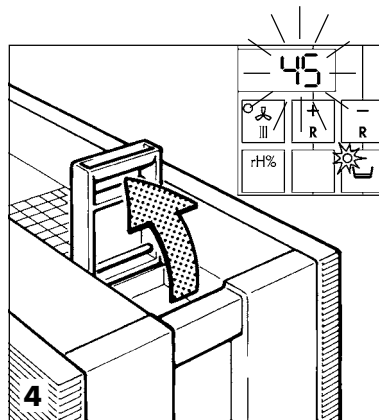

Fill the water tanks with tap water.

Note: Water additives can adversely affect the purification efficiency of the activated carbon evaporator mat.

Use only additives that are guaranteed not to cause any injuries to health and that are marked GRAS (Generally Recognized As Safe).

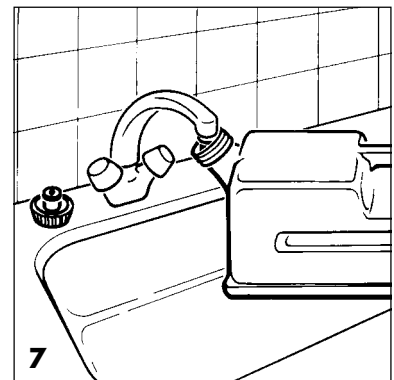
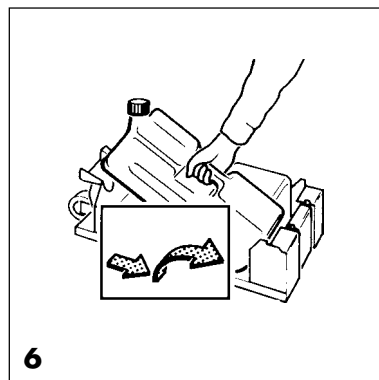

Appliance operation

Switch on the appliance

- Press the **ON/OFF** button.
Select the level (I, II or III) that corresponds to the conditions of your room (see technical data on page 21).
- When operating the appliance for the **first time**, press the two "R" buttons simultaneously for at least 3 seconds (Reset function: see page 26).

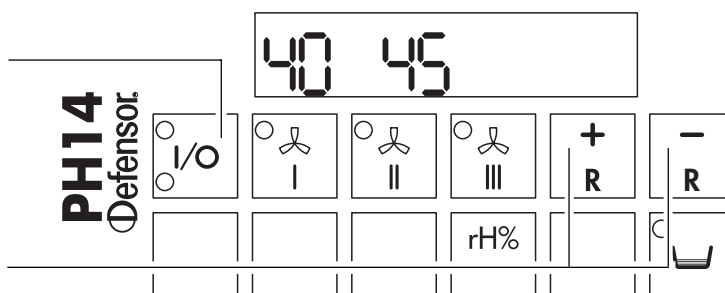

Choose operation mode

- **Purifying and humidifying**
Ex factory or after a reset (see page 26) the unit works in operation mode "Purifying and humidifying": After reaching the nominal humidity the centrifuge stops and the fan continues running.
- **Humidifying only**
Pressing the fan keys "I" and "II" simultaneously for at least 3 seconds switches the operation mode to "Humidifying only": After reaching the nominal humidity the centrifuge and the fan stop simultaneously. Every 15 minutes the fan starts for 5 seconds to prevent an accumulation of moisture in the appliance.
Pressing the fan keys "II" and "III" simultaneously for at least 3 seconds switches the operation mode back to "Purifying and humidifying".

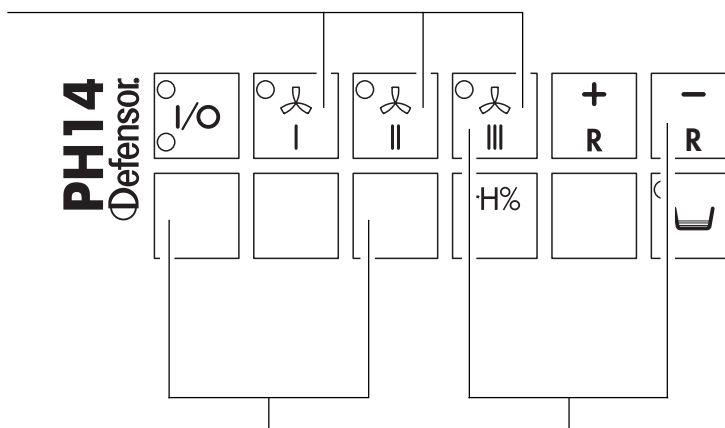

To lock the setting:

- Press these two buttons simultaneously for a minimum of 3 seconds. All settings are locked (on/off incl.). Unlock the setting in the same manner.

The "water low" display blinks when the PH14 is used as an air purifier without water.

- The water low display can be switched off by pressing these two buttons simultaneously for at least 3 seconds. The display is again ready for operation as soon as the appliance is refilled with water.

Read the relative humidity of the room air (actual value)

- Press the rH% button.

Set reference value

We recommend a relative humidity of 45% for living areas.

- Press the plus button or the minus button to increase or decrease the reference value.

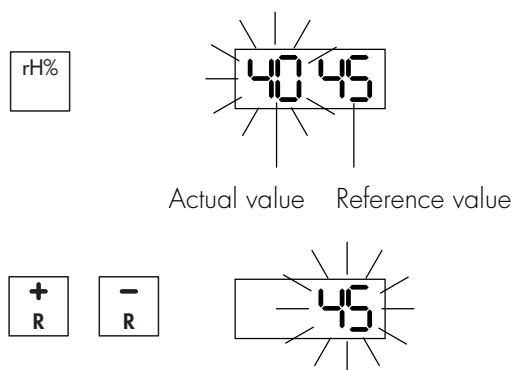

If the appliance has been out of service for a considerable period of time, it takes about 30 minutes before the exact value of the room relative humidity can be displayed. The display is switched off when the wheeled water carriage is removed. After reactivation, the exact relative humidity of the room is displayed after about 1 minute.

Maintenance

Your appliance can only provide full humidification and purification performance if it is regularly cleaned and if necessary the filters respectively the evaporator mat are replaced. Use only a damp cloth (no scouring or etching agents) to clean the outside of the appliance. The cleaning interval is greatly dependent on the operating location. The filters must often be changed when the room air is heavily contaminated. The wet components must often be cleaned if the water is very hard.

• **Clean** these components:

Coarse filter – Coarse dust filter or Quattro filter – Mobile base – Intermediate floor – Water basin – Droplet trap – Flock-coated evaporator mat or Activated carbon evaporator mat

• **Replace** these components:

Coarse filter – Coarse dust filter or Quattro filter – Flock-coated evaporator mat or Activated carbon evaporator mat

Attention! Before starting the maintenance, disconnect the unit from the power supply.

Fig. 1 First withdraw the mains plug and place a cloth on the floor under the wheeled water carriage.

Remove the water carriage.

Fig. 2 Press in the two latches at the bottom of the appliance. If the appliance always remains at the same location, the latches can remain open (they are used only as transport fasteners).

Fig. 3 Lift off the housing.

Bild 4 Lift off the coarse dust filter or Quattro filter and the mobile base cover. Make sure that the coarse dust filter or Quattro filter does not become wet.

Fig. 5 PH14A: Empty the water basin with the supplied pump.

Fig. 6 Lift both retainers.

Press the evaporator mat together and pull it out.

Months

1	2	3	4	5	6	7	8	9	10	11	12

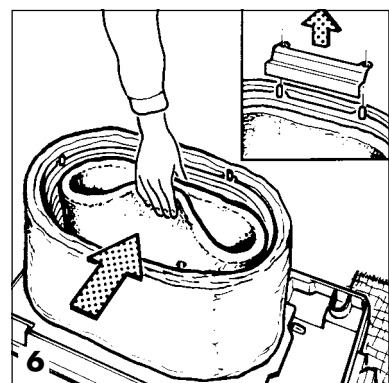
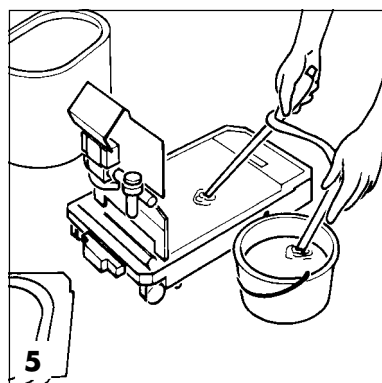
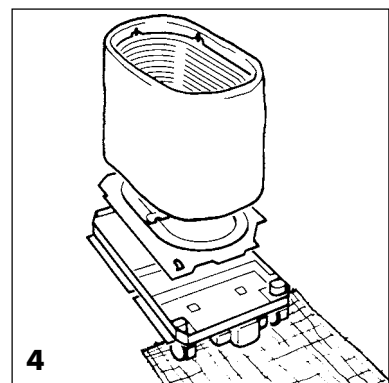
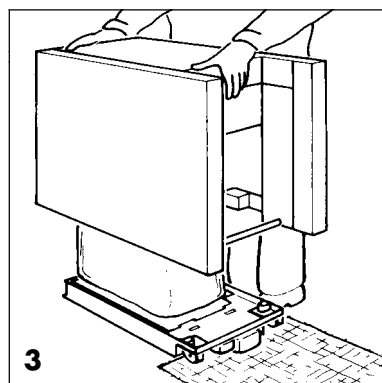
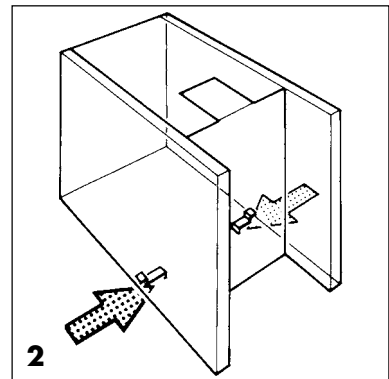
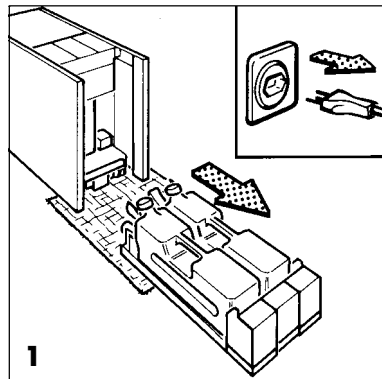

Maintenance

Fig. 1 Pull out the coarse dust filter or Quattro filter.

Clean it with a vacuum cleaner if it is not very dirty.

Replace the coarse dust filter or Quattro filter if it is heavily contaminated.

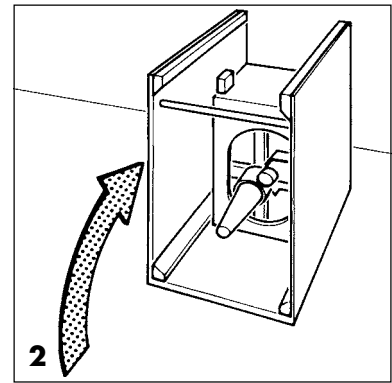
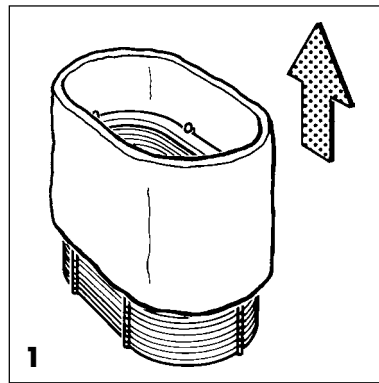

Fig. 2 Tilt the housing.

Fig. 3 Withdraw the centrifuge from the coupling in a straight line.

Clean the float switch (PH14: the safety switch as well).

Fig. 4 Clean the centrifuge with the supplied brush.

Make sure that the centrifuge engages correctly when you reinsert it (Vibrations can occur if it is not correctly located).

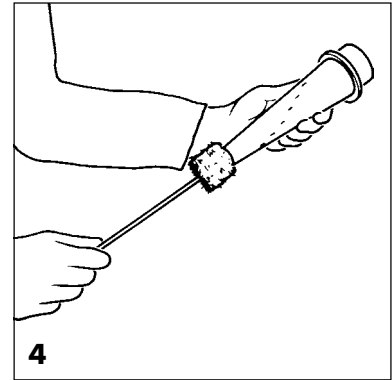
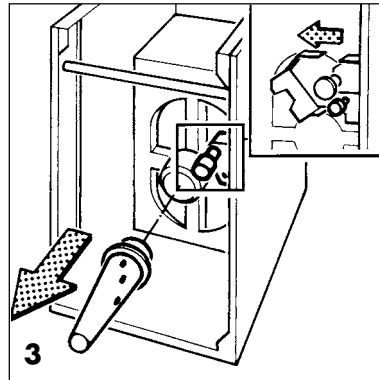

Fig. 5 PH14: Clean the evaporator mat, droplet trap, mobile base cover and mobile base.

Fig. 6 PH14A: Also clean the water basin.

Clean the evaporator mat with luke-warm water only. Use no cleaning agents.

Clean the other components from time to time (Figs. 5 and 6) with a decalcifying agent or with vinegar.

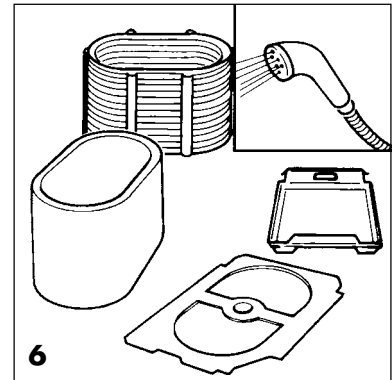
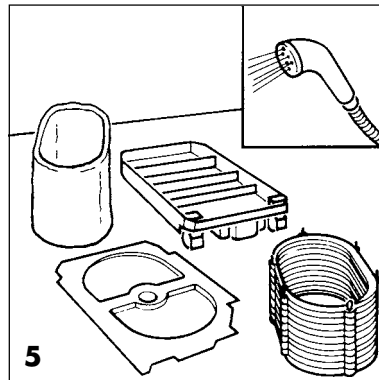
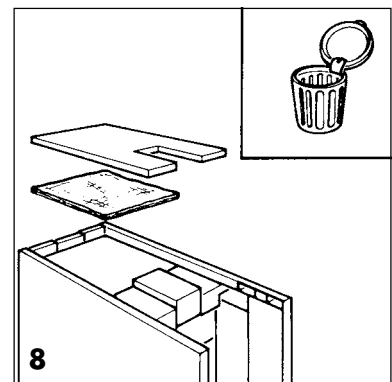
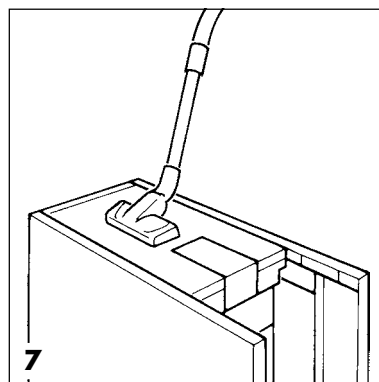

Fig. 7 Clean the coarse filter with the vacuum cleaner if it is not very dirty.

Fig. 8 Replace it if it is heavily contaminated.



Maintenance

Fig. 1 PH14A: Unscrew the strainer housing and clean the strainer insert with warm tap water.

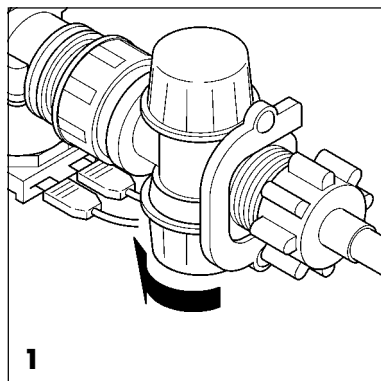
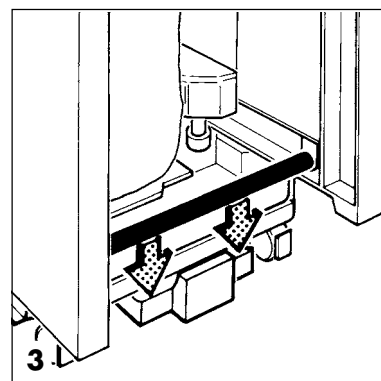
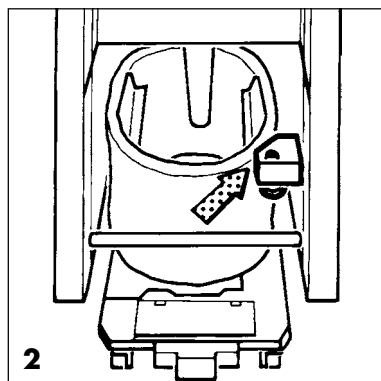

Fig. 2 When replacing the appliance housing, take care that the level switch cover on the Quattro filter slides past freely.

Fig. 3 Locate the cross bar exactly in the recess.

Note: Rinse the unit thoroughly after extended periods of storage and after deliming!



Additional maintenance for the PH14(A)plus

Using a dry cloth, clean the ionization needle each time you clean the appliance.

Replace the needle after about one year of operation. You can remove the needle straight out and insert a new one with a pair of tweezers.

Technical data

Dimensions (WxHxD)	cm	73 x 61 x 37		
Weight (without water)	kg	25		
Water tank capacity	l	2 x 10		
Ambient temperature range	°C	5 – 50		
Ambient humidity range	% r.h.	0 – 85		
Capacity levels		I	II	III
Air circulation rate	m ³ /h	180	280	360
Humidification capacity (at 23° C/45% r.h.)	l/h	0.6	0.9	1.2
Sound power level (DIN45635)	dB(A)	41	49	56
Filter area	m ²	0.4		
Effectiveness against atmospheric dust	%	82		
Retention of synthetic dust of the Quattro filter	%	> 99		
Mains voltage	VAC	100 ... 120/220 ... 240		
Mains frequency	Hz	50/60		
Power consumption	W	max. 55		
Test marks		SEV, VDE, GS, CE		
PH14A:				
Water connection (outer Ø)	mm	12		
Water supply pressure	bar	0.5 – 6		
Feed water temperature range	°C	5 – 40		
PH14(A)plus:				
Negative ions	Neg. ions/ cm ³	300 – 600'000		
Output-tension of ionisator	kV (negative)	6.5		

Maximum room sizes

Capacity level	Room size for air humidification (at 2.5 g/hr x m ³ moisture requirement)	Room size for air purification (at a circulation of 1 to 4 room volumes per hour)
I	max. 180 m ³	max. 45 m ³ to 180 m ³
II	max. 280 m ³	max. 70 m ³ to 280 m ³
III	max. 360 m ³	max. 90 m ³ to 360 m ³

Example 1: You wish to humidify the air in a room 2.5 m high and a floor area of 80 m²:
 $80 \text{ m}^2 \times 2.5 \text{ m} = 200 \text{ m}^3$
 Depending on the natural air humidity, the air in this room can be humidified with the PH14 set to level I or II.

Example 2: You wish to purify the air in a room 3.2 m high and a floor area of 110 m²:
 $110 \text{ m}^2 \times 3.2 \text{ m} = 352 \text{ m}^3$
 The air in this room can be circulated once per hour with the PH14 set to level III.

What, if?

Malfunction	Cause	Remedy
 PH14A only: red lamp adjacent to ON/OFF button lights "Help" display blinks	Water level in basin is too high	<ul style="list-style-type: none"> • Empty basin with pump • Clean or replace safety switch • Call Defensor service organization, if necessary
 Yellow lamp lights and reference value blinks	No water in mobile base or in water basin	PH14: <ul style="list-style-type: none"> • Refill water tanks • Check water supply • Clean float switch PH14A: <ul style="list-style-type: none"> • Clean strainer insert and/or replace it • Clean float switch • Contact Defensor representative
Room does not reach set relative humidity (reference value)	<ul style="list-style-type: none"> – Evaporator mat is missing – Room temperature is too high – Appliance very dirty – Doors or windows are open – Frequent, prolonged ventilation of the room (therefore continuous replacement of humidified room air by dry outdoor air) – Room too large 	<ul style="list-style-type: none"> • Install new evaporator mat • Reduce room temperature to between 20 and 22° C • Perform maintenance (see pages 18 – 20) • Close doors and windows • Ventilate for only a short time (your appliance purifies the room air) • You require more than one appliance
Indicators do not light	Handle not correctly engaged Mains plug withdrawn	<ul style="list-style-type: none"> • Engage handle • Check mains connection • Check mains fuse for the room
Reference value is noticeably exceeded	Natural air humidity is higher than set air humidity (reference value)	Your appliance can continue to operate to purify room air
After filling the water tank or after withdrawing mains plug or after a power supply interruption the appliance does not switch to the previously set fan speed	Backup battery is flat	Have Defensor representative replace battery

Guarantee: Your PH14 air purifier-humidifier has been thoroughly tested and inspected prior to leaving the production factory. The guarantee is effective for one year from the date of purchase. All parts which are defective due to material or manufacturing faults will be replaced free of charge during this period. The guarantee does not cover:

- Defects caused by improper use or repairs attempted by the user.
- Parts which are subject to natural wear as a result of their function.

Retain the original packing for returning a defective appliance. This packing provides the appliance with the best protection against shipping damage.

Important! The power lead may be replaced only by an electrician or an authorized Defensor representative.

Setting the timer/ionization

Activate ion generator

When the negative ion generator is activated, the smallest, health-hazardous particles such as tobacco smoke and soot are also removed from the air.

Negative ions attract floating dust particles and combine with further dust particles to form what are known as clusters, which due to their size are effectively trapped by the air filter.

The ionization of the air also reduces electrostatic charges.



Caution! Most of the dust clusters formed by ionization is trapped by the air filter. However, particularly if the room air is heavily polluted, some of these clusters may cling to walls and other surfaces in the room. Do not position your PH14plus near a wall or curtain. No liability can be assumed for any surface deposits that may occur.

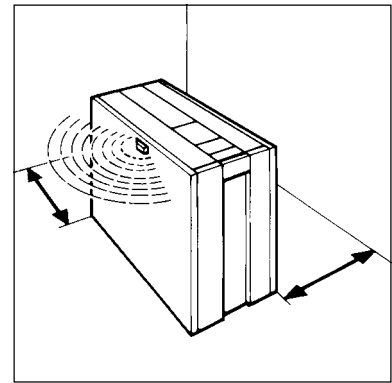

Setting the timer:

Check clock time

- Press the "Set" button

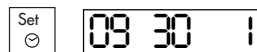

The set time and set day of the week now appear (Monday = 1 ... Sunday = 7).

Setting the clock

- Simultaneously press the "Set" and "rH%" buttons.

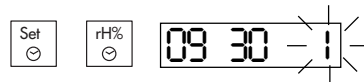

You can now set the time and day of the week.

Example:

Your appliance indicates 09.30, Monday (= 1).

However, it is 14.10, Wednesday (= 3).

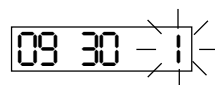

First set the day of the week.

- Press the "+" button until "3" appears.
- Press the "Set" button and set the hours.
- Press the "Set" button and set the minutes.
- Press the "Set" button again.

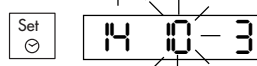
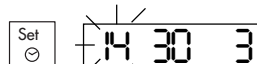
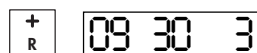

After about 10 seconds, your appliance will again display the reference value of the room air humidity.

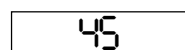

Setting the timer

Function

Up to 4 switching times are available for each day of the week.

The following settings can be made for each switching time.

- Weekday (1-7 = Mon-Sun)
- Hour (0-24)
- Minutes (0-60)
- Fan speed (I/II/III)
- Zero fan speed (switch off)

The settings always determines the operating state until the next switching time. In the example, the appliance switches to level 1 on Tuesday at 13.00 hours. The appliance will continue to run at this level during the following day and will change to level III at 12.00 hours on Wednesday.

Example:

Monday

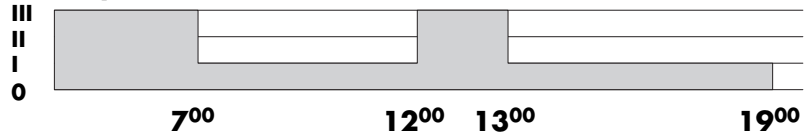

Tuesday

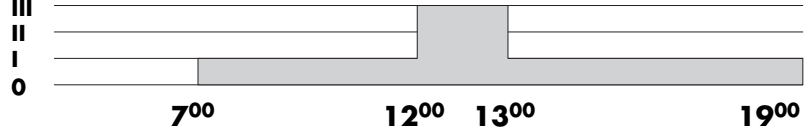

Wednesday

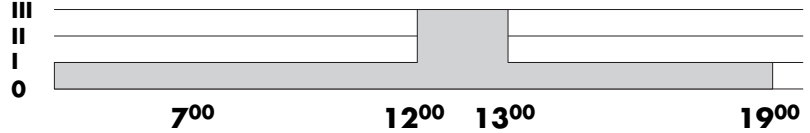

Thursday

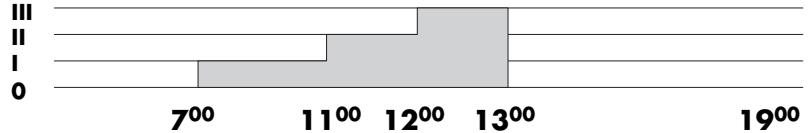

Friday

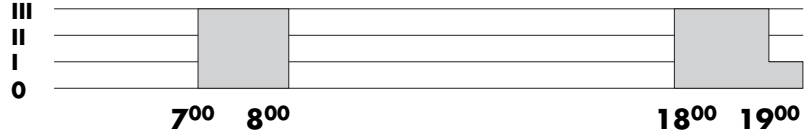

Saturday

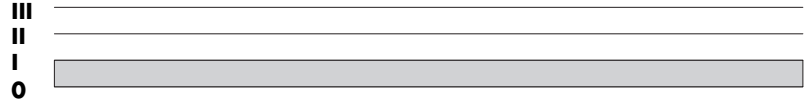

Sunday

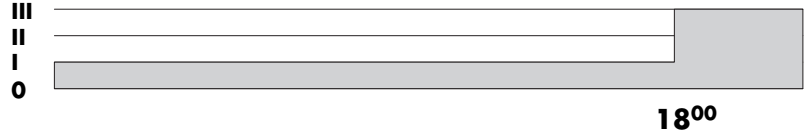

Set the switching times for Tuesday and Wednesday (see example).

Proceed in the following matter:

- Press button "P" for 3 seconds. The day display blinks. You can now set the switching times.
- Set the day with the "+/-" buttons (Tuesday = 2 in the example).
- Press "Set" and set the hours (07 in the example).
- Press "Set" and set the minutes (00 in the example).
- Press "Set" and select the fan speed. Also press the respective fan button (speed I in the example).

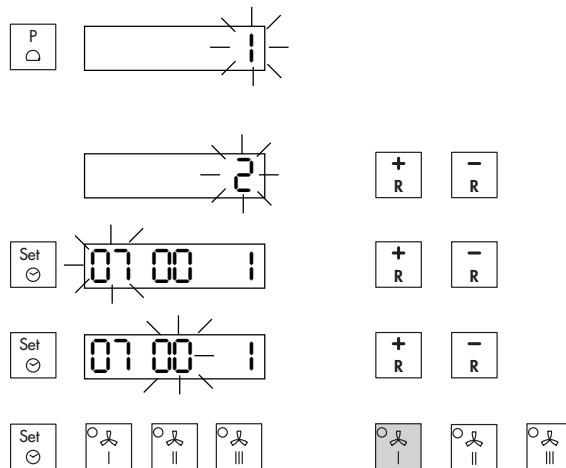

Setting the timer

- Press "Set". You can now set the other switching times for Tuesday.



Second switching time Tuesday

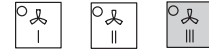
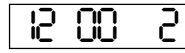

Third switching time Tuesday

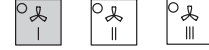

Since you do not need a fourth switching time, simply press "Set" until the clock time is displayed. Ten seconds later, the air-humidity reference value appears. You have then set all the switching times for Tuesday.



Now set the times for Wednesday. Press the "P" button again for 3 seconds and set "3" for the day of the week, then proceed in the same manner as before:

First switching time Wednesday

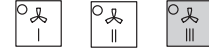
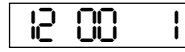

Second switching time Wednesday

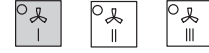
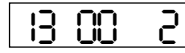

Third switching time Wednesday

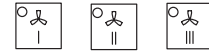
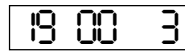

To ensure that the appliance is switched off at 19.00, press "Set" instead of selecting a fan speed.

Again press "Set" several times until the clock time, or after 10 seconds, the air humidity is displayed. You have now set the switching times for Wednesday.

Accessing the switching times

- Press the "P" and "Auto" buttons simultaneously. The day display blinks.

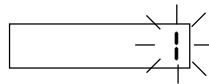

Select the day with the "+/-" buttons (Tuesday = 2 in the example)

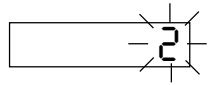

- Press "Set". You now see the first (of 4) switching times for the selected day and the selected fan speed.

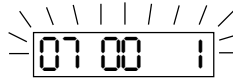

- Press "Set" for the second, third and fourth switching times.



- Again press "Set".



Your appliance now displays the clock time and, after 10 seconds, the reference value of the room-air humidity.

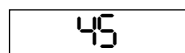

Repeat the accessing operation for the other days of the week.

Setting the timer

Automatic timer ON/OFF

Press the "Auto" button to switch the automatic timer on or off.

The appliance can be operated as usual in the automatic operating mode.

The fan speeds can be changed at will and the appliance can also be switched on or off

However, the appliance may not respond to a button being pressed because the automatic timer is active at that moment. Try again about 2 minutes later.

At the next switching time, the automatic timer again sets the value which you determined when setting the switching time.

Reset

All switching times and the clock time can be set to zero by pressing both "R" buttons. The reference value for the air humidity is set to 45% at the same time.

Pressing the "Reset" buttons can remedy malfunctions of the appliance control system.

The reset function is not in operation when you have locked the settings (see "Lock setting").

Lock setting

You can lock the set switching times against inadvertent change (see page 17).

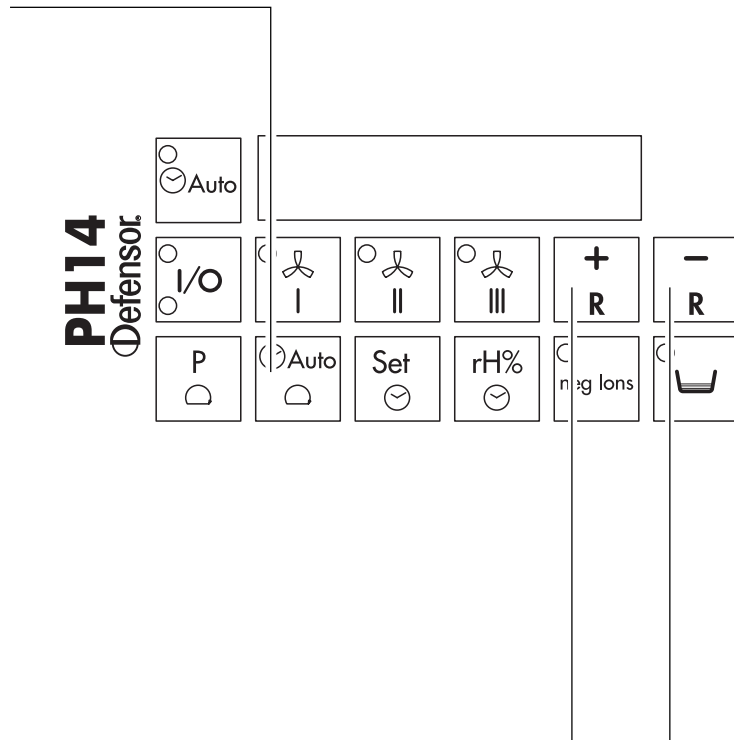

Constitution, fonctionnement, implanatation

Constitution

- 1 Grille d'aspiration de l'air
- 2 Filtre à poussière grossier
- 3 Ventilateur
- 4 Pompe centrifuge
- 5 Chambre de lavage
- 6 Natte d'évaporation à couche floconneuse ou natte d'évaporation à charbon actif
- 7 Élément séparateur
- 8 Filtre à poussière grossier ou filtre Quattro
- 9 Réservoir à eau
- 10 Châssis roulant (avec bac à eau PH14A)
- 11 Chariot à eau

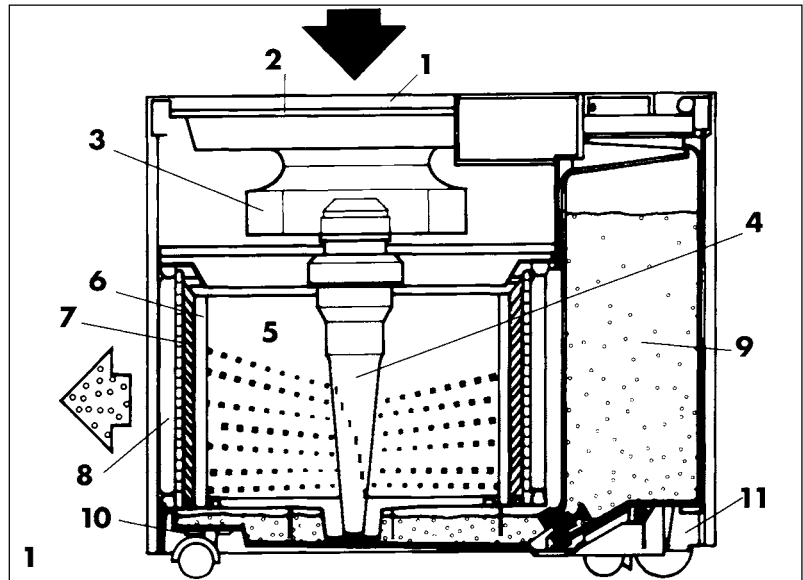

Fonctionnement

L'appareil mesure en permanence l'humidité du local (valeur effective) et la compare avec la valeur de consigne réglée.

La valeur effective affichée peut diverger de la valeur de consigne. Si cette dernière est dépassée vers le bas pendant une durée prolongée, l'appareil doit être réglé au gradin de puissance plus élevé suivant.

Si l'appareil doit fonctionner pendant une durée prolongée uniquement pour la purification de l'air, vider les réservoirs à eau, resp. fermer la vanne de l'alimentation d'eau (PH14A).

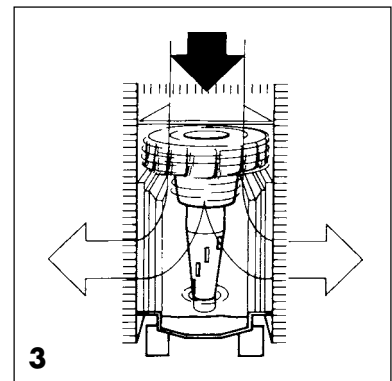
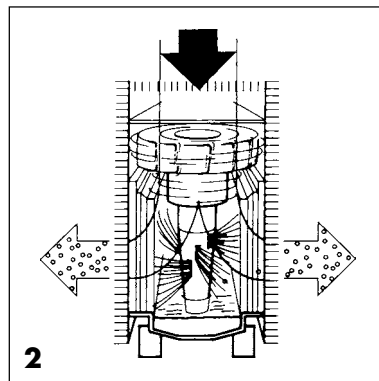

Choix de l'implantation

Figure 4 On obtient une circulation optimale de l'air du local en évitant de placer l'appareil directement contre une paroi. Placer l'appareil sur une surface horizontale, si possible en position indépendante et facilement accessible.

Ne pas placer l'appareil derrière des rideaux qui entraveraient la circulation de l'air.

Si l'appareil est placé sous une table, la distance entre la table et l'appareil doit être d'au moins 10 cm.
Ne pas placer des objets sur l'appareil. Il en résulterait une diminution des performances.

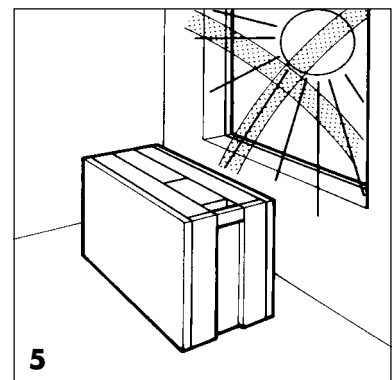
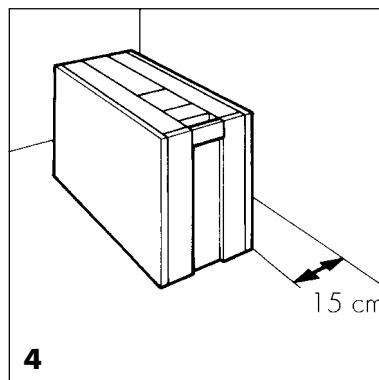

Prudence en cas de déplacement de l'appareil PH14. Ne pas soulever l'appareil (danger d'écoulement d'eau sur le sol).

Une insolation prolongée est nuisible pour l'appareil.

Installation/manipulation

Branchement de l'eau (PH14A)

Figure 1 Faire installer l'appareil par un spécialiste (valeurs de branchement, voir "Données techniques", page 33).

Avant l'enclenchement de l'appareil, s'assurer que la vanne d'alimentation d'eau est ouverte.

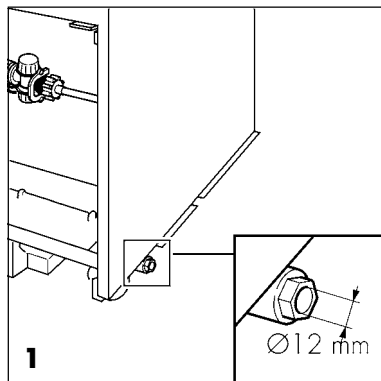

Contrôler la tension du réseau

Figure 2 S'assurer que la tension indiquée sur la plaquette signalétique correspond à celle du réseau.

Attention! Ne pas brancher l'appareil si cette indication ne correspond pas à la tension locale du réseau!

Blocage des rouleaux

Figure 3 Bloquer les rouleaux lorsque l'appareil se trouve à l'endroit voulu.

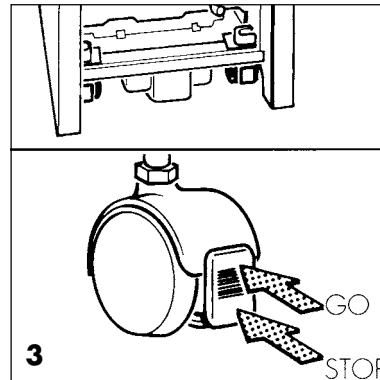
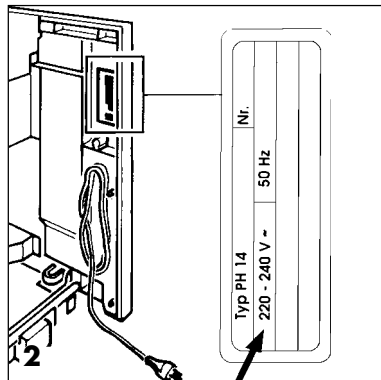

Remplissage d'eau (PH 14)

Figures 4-7 Lorsque l'affichage de la valeur de consigne clignote et que la lampe "Manque d'eau" est allumée, cela signifie que les réservoirs sont vides. Placer un chiffon sur le sol avant d'extraire le chariot à eau, afin d'éviter le mouillage du sol.

Soulever la poignée et extraire le chariot, ou déposer le chariot sur le sol et extraire individuellement les réservoirs.

Remplir les réservoirs avec d'eau du réseau.

Attention! Des adjuvants à l'eau peuvent entraver le bon fonctionnement de la natte d'évaporation à charbon actif. N'utiliser que des adjuvants excluant tout dommage pour la santé – également à longue échéance. Observer l'attestation de non-nuisance.

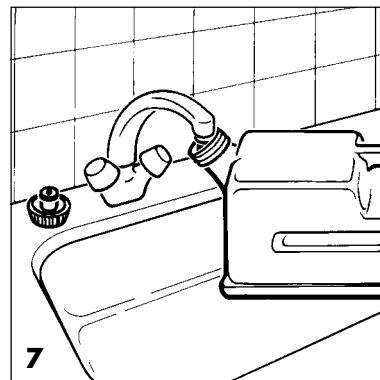
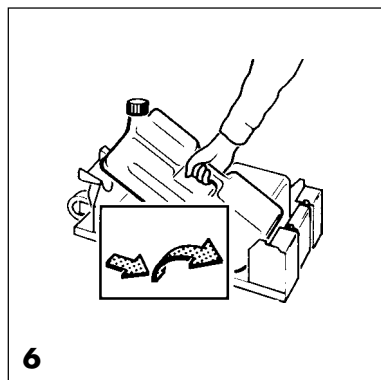
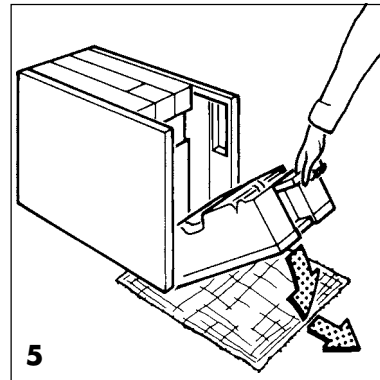
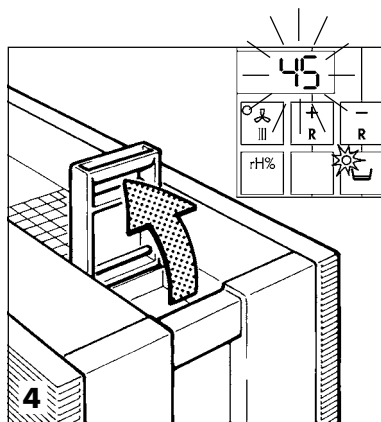

Manipulation

Enclencher l'appareil

- Actionner la touche **En/Hors**.
Sélectionner les gradins de puissance I, II ou III en fonction de la grandeur du local (voir "Données techniques", page 33).
- Lors de la **première mise en service**, actionner simultanément les deux touches "R" pendant au moins 3 secondes (fonction Reset: voir page 38).

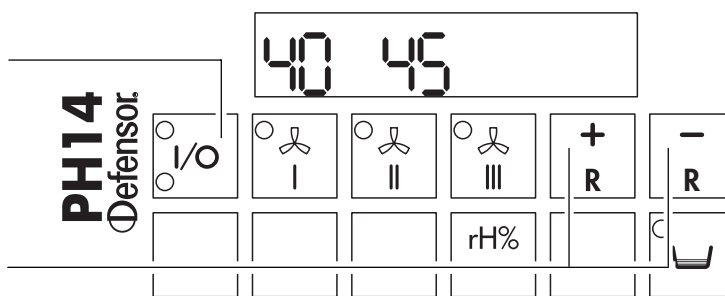

Choisir le mode de service

- **Purification et humidification**
Départ usine ou après un Reset (voir page 38) l'appareil fonctionne en mode "**Purification et humidification**": après l'humidité nominale est atteinte la pompe centrifuge s'arrête mais le ventilateur continue à tourner.
- **Humidification uniquement**
En pressant simultanément les touches ventilateur "I" et "II" au moins 3 secondes vous commuterez en mode "**Humidification uniquement**": après l'humidité nominale est atteinte la pompe centrifuge et le ventilateur s'arrêtent en même temps. Toutes les 15 minutes le ventilateur se met en marche pour 5 secondes, pour éviter une accumulation d'humidité dans l'appareil.
En pressant simultanément les touches ventilateur "II" et "III" au moins 3 secondes vous commuterez en mode "Purification et humidification"

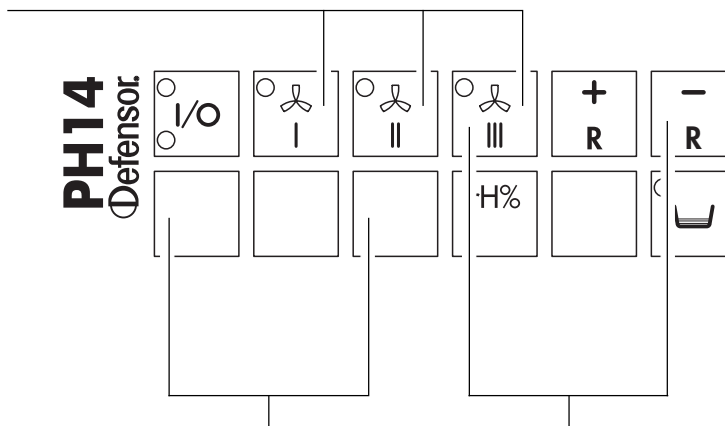

Pour **assurer le réglage** contre les modifications:

- Presser simultanément pendant au moins 3 secondes ces deux touches. A ce moment, tous les réglages restent conservés (la touche En/Hors inclus). Pour débloquer le réglage, on procède de la même façon.

Lors de l'utilisation du PH14 comme purificateur de l'air sans eau, l'affichage du manque d'eau clignote.

- En pressant simultanément pendant au moins 3 secondes ces deux touches, **l'affichage du manque d'eau est enclenché**. Dès qu'on remplit de l'eau, l'affichage est de nouveau prêt au service.

Lecture de l'humidité de l'air ambiant (valeur effective)

- Actionner la touche rH%.

Réglage de la valeur de consigne

Pour les pièces d'habitation, nous recommandons une humidité relative de 45%.

- Actionner la touche "+" ou la touche "-" pour augmenter ou diminuer la valeur de consigne.

Après un arrêt prolongé de l'appareil, l'humidité précise de la pièce ne peut être lue qu'après env. 30 minutes.

Lors de l'extraction du chariot à eau, l'affichage se déclenche. Après le nouvel enclenchement, l'humidité précise de l'air de la pièce peut être lue après env. 1 minute.

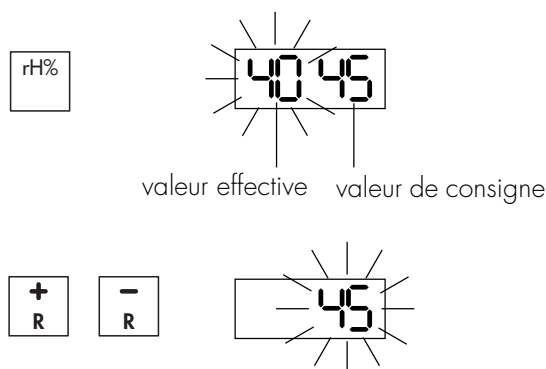

Maintenance

L'appareil ne fournit toutes ses performances d'humidification et de purification que s'il est nettoyé régulièrement et que si les pièces d'usure usées sont remplacées. Ne nettoyer l'extérieur de l'appareil qu'avec un chiffon humide, sans produit abrasif ou corrodant. Les intervalles du nettoyage dépendent fortement du lieu d'utilisation. En cas d'air ambiant fortement pollué, les filtres doivent être remplacés plus fréquemment.

Si l'eau est très dure, les composants mouillés doivent être nettoyés plus souvent.

- Nettoyer ces composants:
Filtre grossier – Filtre à poussière grossier ou Filtre Quattro – Châssis roulant – Fond intermédiaire – Bac à eau – Élément séparateur – Natte d'évaporation à couche floconneuse ou Natte d'évaporation à charbon actif
- Changer ces composants:
Filtre grossier – Filtre à poussière grossier ou Filtre Quattro – Natte d'évaporation à couche floconneuse ou Natte d'évaporation à charbon actif

Attention! Avant de commencer avec la maintenance, débranchez l'appareil du réseau électrique.

Figure 1 Retirer tout d'abord la fiche du réseau et placer un chiffon sur le sol, sous le chariot à eau.

Extraire le chariot à eau.

Figure 2 Presser les deux verrouillages sous l'appareil vers l'intérieur. Si l'appareil reste sur place, les verrouillages peuvent rester ouverts (ils ne servent que de sécurité pour le transport).

Figure 3 Soulever le boîtier.

Figure 4 Enlever le filtre à poussière grossier ou le filtre Quattro et le fond intermédiaire.









Veiller à ne pas mouiller le filtre à poussière grossier ou le filtre Quattro.

Figure 5 PH14A: Vider le bac à eau avec la pompe fournie avec l'appareil.

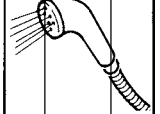
Figure 6 Déposer les deux supports.

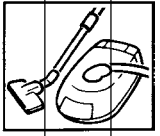
Presser et extraire la natte d'évaporation.

Mois

1	2	3	4	5	6	7	8	9	10	11	12
											
											
											

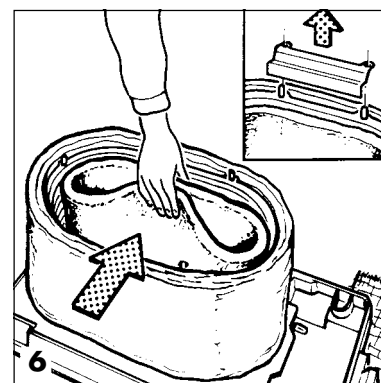
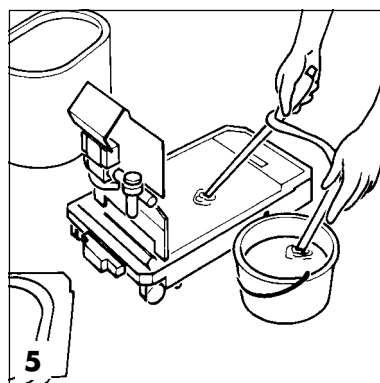
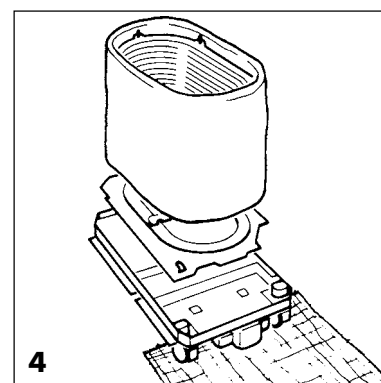
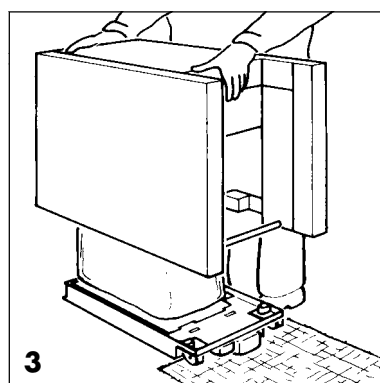
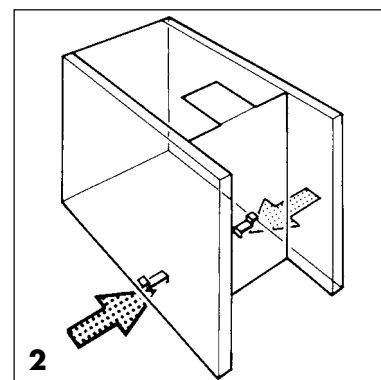
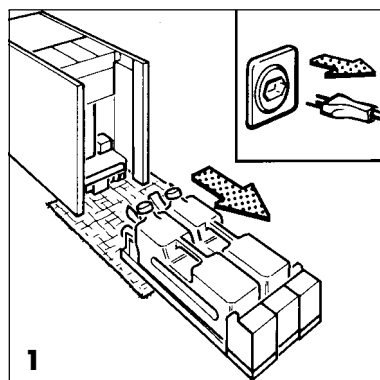

Maintenance

Figure 1 Démontez le filtre à poussière grossier ou le filtre Quattro.
En cas de salissure légère, nettoyez avec un aspirateur à poussière.
En cas de forte salissure, remplacez.

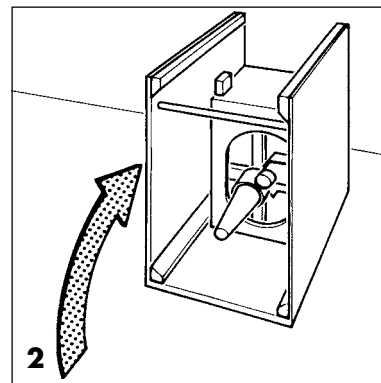
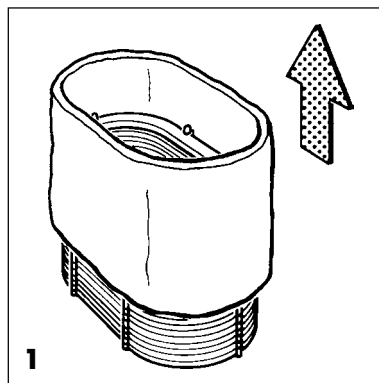

Figure 2 Faire basculer le boîtier.

Figure 3 Retirez en ligne droite la pompe centrifuge hors de l'accouplement.
Nettoyez l'interrupteur à flotteur (PH14A: interrupteur de sécurité supplémentaire).

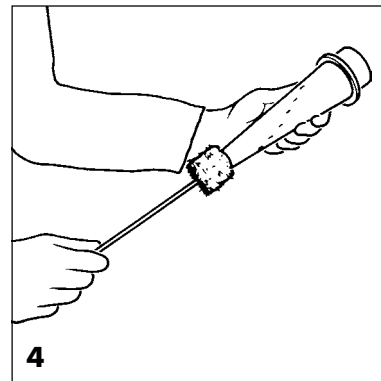
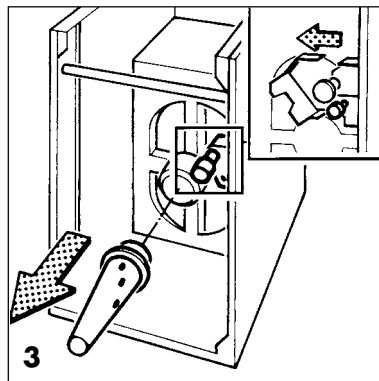

Figure 4 Nettoyez la pompe centrifuge avec la brosse fournie avec l'appareil.
Lors du nouveau montage de la pompe centrifuge, s'assurez qu'elle s'encliquette correctement (sinon, des vibrations peuvent se produire).

Figure 5 PH14: Nettoyez la natte d'évaporation, l'élément séparateur, le fond intermédiaire et le châssis roulant.

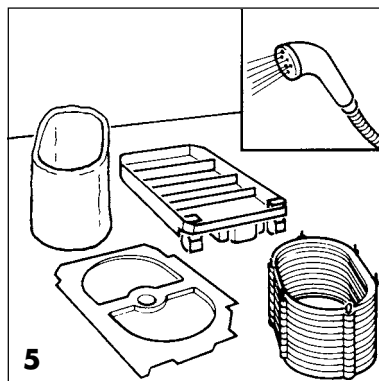

Figure 6 PH14A: Nettoyez en outre le bac à eau. Nettoyez la natte d'évaporation uniquement avec de l'eau tiède, sans produit de nettoyage. Nettoyez de temps en temps les autres composants (Figures 5 et 6) avec un produit de détartrage ou du vinaigre.

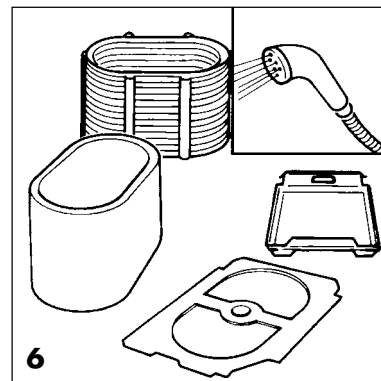

Figure 7 Nettoyez le filtre grossier avec un aspirateur à poussière en cas de salissure légère.

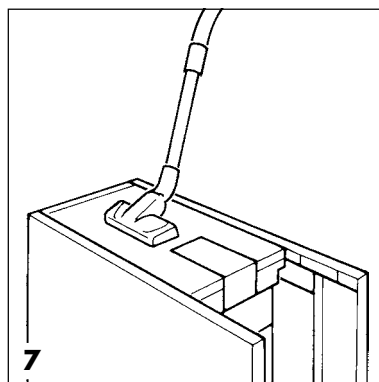
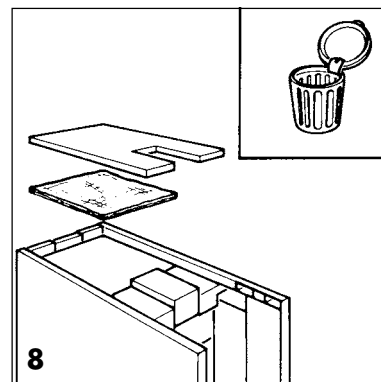

Figure 8 Remplacez ce filtre s'il est fortement encrassé.



Maintenance

Figure 1 PH14A: Dévisser l'embout inférieure du filtre à tamis et nettoyer le filtre sous l'eau courante chaude.

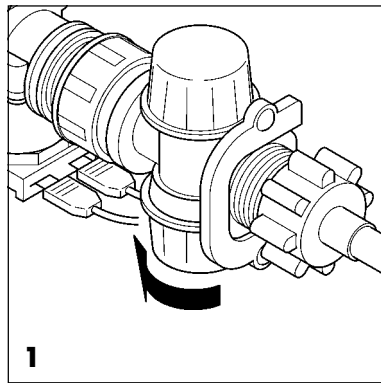

Figure 2 Lors du montage du boîtier, veiller à ce que le carter de l'interrupteur à flotteur passe le long du filtre Quattro.

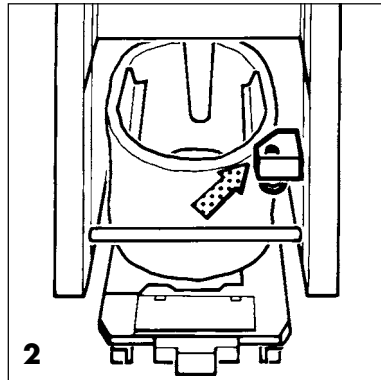
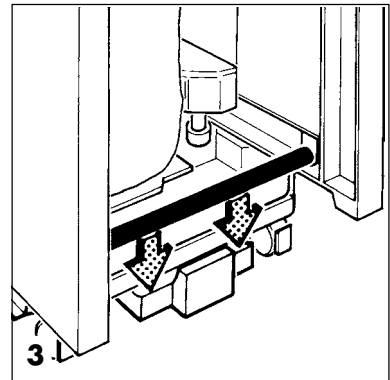

Figure 3 La barre transversale doit être introduite exactement dans l'évidement.



Attention! En cas d'inutilisation prolongée et après la décalcification, bien rincer l'appareil!

Maintenance supplémentaire pour le PH14(A)plus

Nettoyer l'aiguille d'ionisation avec un petit chiffon lors de chaque entretien de l'appareil. Après environ une année, les aiguilles d'ionisation devraient être remplacées. L'aiguille se retire en l'extrayant en ligne droite avec une pincette et la nouvelle se met en place en la pressant avec la pincette dans son logement.

Données techniques

Dimension (LxHxP)	cm	73 x 61 x 37		
Poids (sans eau)	kg	25		
Contenance du réservoir à eau	l	2 x 10		
Température ambiante	°C	5 – 50		
Humidité ambiante	% hr	0 – 85		
Gradin de puissance		I	II	III
Circulation d'air	m ³ /h	180	280	360
Humidification (à 23 °C/45% hr)	l/h	0.6	0.9	1.2
Niveau sonore (DIN45635)	dB(A)	41	49	56
Surface du filtre	m ²	0.4		
Rendement en cas de poussière atmosphérique	%	82		
Degré de séparation filtre Quattro en cas de poussière synthétique	%	>99		
Tension du réseau	V ~	100...120/220...240		
Fréquence du réseau	Hz	50/60		
Puissance absorbée	W	max. 55		
Homologation		SEV, VDE, GS, CE		
PH14A:				
Branch. de l'eau (Ø extérieur)	mm	12		
Pression de réseau	bar	0.5 – 6		
Température d'aliment. de l'eau	°C	5 – 40		
PH14(A)plus:				
Ionisation négative	ion neg./cm ³	300 – 600'000		
Tension de sortie du ionisateur	kV (négatif)	6.5		

Grandeur maximale du local

Gradin de puissance	Grandeur du local pour l'humidification de l'air (pour un besoin d'humidité de 2,5 g/h · m ³)	Grandeur du local pour la purification de l'air (à 1 – 4 circulations d'air par heure)
I	max. 180 m ³	max. 45 m ³ bis 180 m ³
II	max. 280 m ³	max. 70 m ³ bis 280 m ³
III	max. 360 m ³	max. 90 m ³ bis 360 m ³

Exemple 1: On veut humidifier l'air d'un local d'une superficie de 80 m² et d'une hauteur de 2,5 m.
80 m² x 2,5 m = 200 m³
Avec un PH14, l'air de ce local peut être humidifié sur les gradins I ou II, selon l'humidité naturelle.

Exemple 2: On veut purifier l'air d'un local d'une superficie de 110 m² et d'une hauteur de 3,2 m.
110 m² x 3,2 m = 352 m³
Avec un PH14, l'air de ce local peut être purifié sur le gradin III avec une circulation d'une fois par heure.

Que faire si?

Dérangement	Cause	Dépannage
 Uniquement PH14A: La lampe rouge près de la touche I/O est illuminée. L'affichage "Help" clignote	Le niveau de l'eau dans le bac est trop haut.	<ul style="list-style-type: none"> • Vider le bac à eau avec la pompe • Nettoyer ou remplacer l'interrupteur de sécurité • Contacter évent. votre fournisseur Defensor
 La lampe jaune est illuminée et la valeur de consigne clignote	Pas d'eau dans le châssis roulant, resp. dans le bac à eau	PH14: <ul style="list-style-type: none"> • Remplir le réservoir à eau • Contrôler l'alimentation en eau • Nettoyer l'interrupteur à flotteur PH14A: • Nettoyer l'insertion du filtre à tamis ou remplacer le • Nettoyer l'interrupteur à flotteur • Contacter évent. votre fournisseur Defensor
L'air ambiant n'atteint pas l'humidité réglée (valeur de consigne)	<ul style="list-style-type: none"> – Natte d'évaporation absente – Température élevée dans la pièce – Appareil fortement encrassé – Portes ou fenêtres ouvertes – Aérations fréquentes et longues de la pièce (donc échange permanent de l'air humide du local contre de l'air sec extérieur) – Local trop grand 	<ul style="list-style-type: none"> • Installer une nouvelle natte d'évaporation • Réduire la température de la pièce à 20 - 22 °C • Procéder à la maintenance (pages 30 – 32) • Fermer les portes et les fenêtres • N'aérer que brièvement (l'appareil purifie l'air du local) • Utiliser plus qu'un appareil
Les affichages ne sont pas illuminés	La poignée n'est pas encliquetée correctement. La fiche du réseau est retiré	<ul style="list-style-type: none"> • Faire encliqueter la poignée • Contrôler le branchement au réseau • Contrôler les fusibles de l'alimentation électrique
La valeur de consigne est sensiblement dépassée	L'humidité naturelle de l'air est plus élevée que la valeur introduite (valeur de consigne)	On peut laisser marcher l'appareil uniquement pour la purification de l'air du local
Après le remplissage des réservoirs à eau, ou après le retrait de la fiche du réseau, ou après une interruption de courant, l'appareil ne commute pas sur le gradin précédent du ventilateur	La batterie d'appoint est épuisée	Faire remplacer la batterie chez votre fournisseur Defensor

Garantie: Avant de quitter l'atelier, l'humidificateur-purificateur PH14 a été soumis à un contrôle approfondi. La durée de la garantie est d'un an à compter de la date de la facture. Pendant ce temps, toutes les pièces présentant des défauts de matériau ou de fabrication sont remplacées gratuitement. Sont exclus de la garantie:

- Les défauts provoqués par une manipulation erronée ou par des interventions de tiers.
- Les pièces soumises à une usure naturelle en cours de fonctionnement.

Prière d'utiliser l'emballage original en cas de renvoi d'un appareil défectueux. Cet emballage procure une protection optimale pendant le transport.

Attention: Le câble de branchement au réseau ne peut être remplacé que par un négociant spécialisé en appareils électriques ou par votre fournisseur Defensor.

Horloge de commutation/Ionisation

Enclenchement de l'ionisation

Par l'enclenchement du générateur à ions négatifs, l'air de la pièce est libéré des particules de poussière (les plus fines) nocives pour la santé, telles que la fumée de tabac et la suie.

Les ions négatifs attirent les particules de poussière en suspension dans l'air et les associent à d'autres particules pour en former ce qu'on appelle des clusters. En raison de leur grandeur, ceux-ci sont retenus dans le filtre d'air. L'ionisation de l'air diminue en outre les charges électrostatiques.



Attention! La majeure partie des clusters de poussière formés par l'enclenchement de l'ionisation est retenue dans le filtre d'air. Il est cependant possible, spécialement en cas de forte pollution de l'air ambiant, qu'une petite partie des clusters de poussière se dépose sur les parois et les autres surfaces de la pièce. Il est donc recommandé de ne pas placer le PH14plus à proximité immédiate des murs ou des rideaux. Nous n'endossons aucune responsabilité pour des dépôts de poussière superficielles éventuelles.

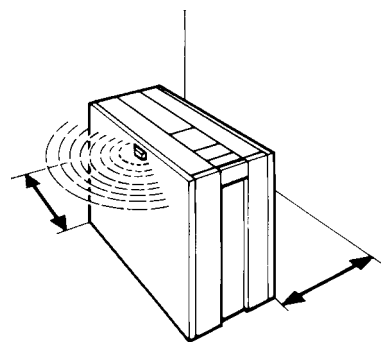

Réglage de l'horloge de commutation:

Contrôle de l'heure

- Presser la touche "Set"

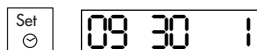

A ce moment, l'affichage présente l'heure réglée et le jour de la semaine (lundi = 1 ... dimanche = 7).

Réglage de l'heure

- Presser en même temps la touche "Set" et la touche "rH%".



A ce moment, on peut modifier l'heure et le jour de la semaine.

Exemple:

L'appareil indique 9 h 30, lundi (= 1)
Il est pourtant 14 h 10, mercredi (= 3)

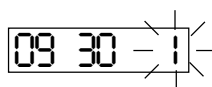

Régler en premier le jour de la semaine

- Presser la touche "+" jusqu'à l'apparition de "3".
- Presser la touche "Set" et régler l'heure.
- Presser la touche "Set" et régler les minutes.
- Presser encore une fois la touche "Set".

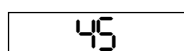
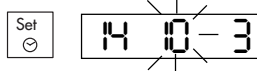
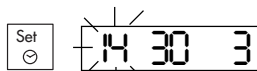
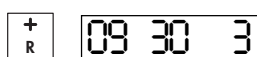

Après env. 10 secondes, l'appareil indique de nouveau la valeur de consigne de l'humidité de l'air.

Réglage de l'horloge de commutation

Fonction

On dispose d'au maximum 4 heures de commutation par jour de la semaine.

Pour chaque heure de commutation, on doit procéder aux réglages suivants:

- Jour de la semaine (1-7 = lu-di)
- Heures (0-24)
- Minutes (0-60)
- Gradins du ventilateur (I/II/III)
- Pas de ventilateur (= déclenchement)

Le réglage détermine toujours l'état de service jusqu'à la prochaine commutation.

Par exemple, l'appareil s'enclenche le mardi à 13 h sur le gradin I. L'appareil fonctionne encore le jour suivant sur ce gradin et ce n'est que l'heure de commutation du mercredi à 12 h qui fait passer l'appareil sur le gradin III.

Exemple:

Lundi

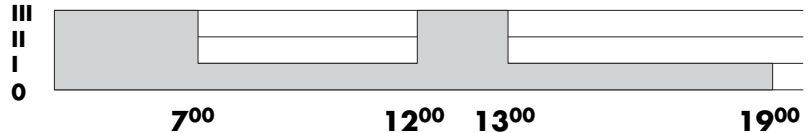

Mardi

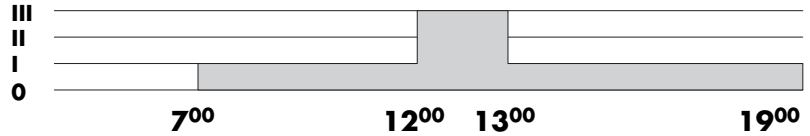

Mercredi

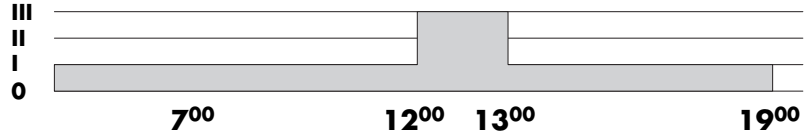

Jeudi

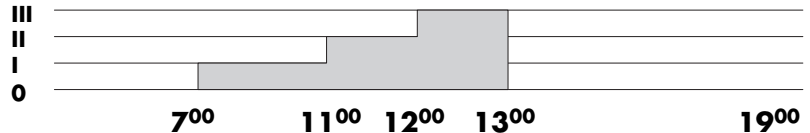

Vendredi

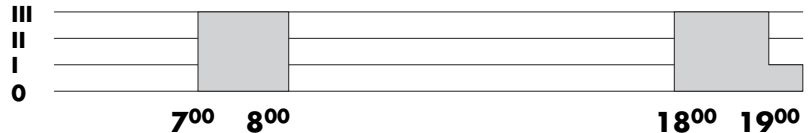

Samedi

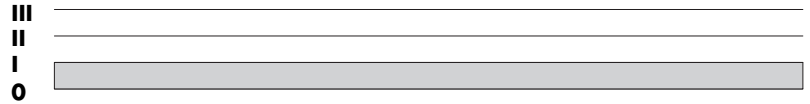

Dimanche

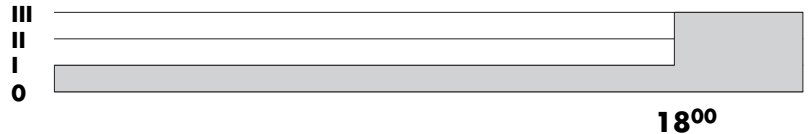

Réglage des heures de commutation du mardi et du mercredi (voir exemple).

A cet effet on procède comme suit:

- Presser la touche "P" pendant 3 secondes. L'affichage du jour clignote. Placer les heures de commutation
- Placer le jour à l'aide des touches "+/-" (dans l'exemple: mardi = 2).
- Presser la touche "Set" et placer les heures (dans l'exemple: 07).
- Presser la touche "Set" et placer les minutes (dans l'exemple: 00).
- Presser la touche "Set" et sélectionner le gradin de la puissance du ventilateur. A cet effet, actionner la touche correspondante (dans l'exemple le gradin II).

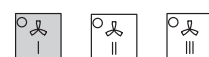
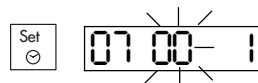
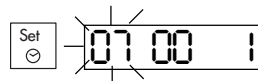
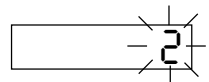
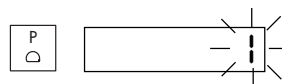

Réglage de l'horloge de commutation

- Presser la touche "Set" et sélectionner les autres heures de commutation du mardi.



2. Heure de commutation du mardi

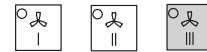

3. Heure de commutation du mardi

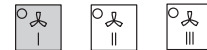
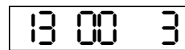

Puisqu'on n'a pas besoin de 4 heures de commutation, il suffit de presser plusieurs fois la touche "Set" jusqu'à la réapparition de l'affichage de l'heure. Après 10 secondes, on obtient de nouveau la valeur de consigne de l'humidité de l'air.



Régler ensuite les heures de commutation du mercredi. Presser de nouveau la touche "P" pendant env. 3 secondes et introduire "3" pour le jour de la semaine. Procéder ensuite comme décrit ci-dessus:

1. Heure de commutation mercredi

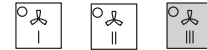
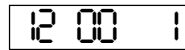

2. Heure de commutation mercredi

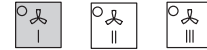
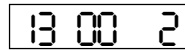

3. Heure de commutation mercredi

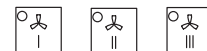
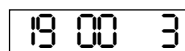

Pour que l'appareil se déclenche à 19 heures, on ne sélectionne aucun gradin de ventilateur, mais on presse la touche "Set".

Presser ensuite plusieurs fois la touche "Set" jusqu'à la réapparition de l'affichage de l'heure. Après 10 secondes, on obtient de nouveau la valeur de consigne de l'humidité de l'air.

Questionnement des heures de commutation

- Presser en même temps les touches "P" et "Auto". L'affichage du jour se met à clignoter. A l'aide de la touche "+ / -", sélectionner le jour (dans l'exemple mardi = 2).

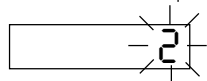
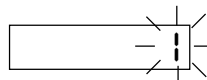

- Presser la touche "Set". L'affichage présente alors la première heure de commutation (parmi les 4) du jour choisi, ainsi que le gradin sélectionné du ventilateur.

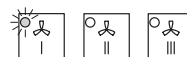

- Presser la touche "Set" pour la deuxième, la troisième et la quatrième heure de commutation.



- Presser encore une fois la touche "Set".



A ce moment, l'appareil indique de nouveau l'heure et après 10 secondes, la valeur de consigne de l'humidité de l'air. Répéter le questionnement pour les autres jours de la semaine.

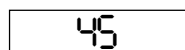

Réglage de l'horloge de commutation

Automatisme de commutation En/Hors

Presser la touche "Auto" pour enclencher et déclencher l'automatisme de commutation. Lorsque le dispositif automatique est en service, l'appareil peut se manipuler comme d'habitude.

Les gradins de puissance du ventilateur peuvent être modifiés à volonté et l'appareil peut aussi être enclencher et déclencher.

Il peut arriver que l'appareil ne réponde pas à un actionnement des touches, parce que l'automatisme de commutation est justement en train de travailler. Procéder à un nouvel essai après env. 2 minutes.

Après la prochaine heure de commutation, l'automatisme de commutation remplacera la valeur introduite lors du réglage de l'heure de commutation.

Reset

En actionnant les deux touches "R", l'heure et toutes les heures de commutation sont remises à zéro. Simultanément, la valeur de consigne de l'humidité de l'air est placée à 45 %.

En cas de fonctionnement erroné de la commande de l'appareil, l'actionnement des touches de reset peut provoquer le dépannage.

La fonction de reset n'est pas en service lorsque les réglages sont assurés (voir "Assurance des réglages").

Assurance des réglages

Les heures de commutation peuvent être assurées contre une modification involontaires (voir page 29).

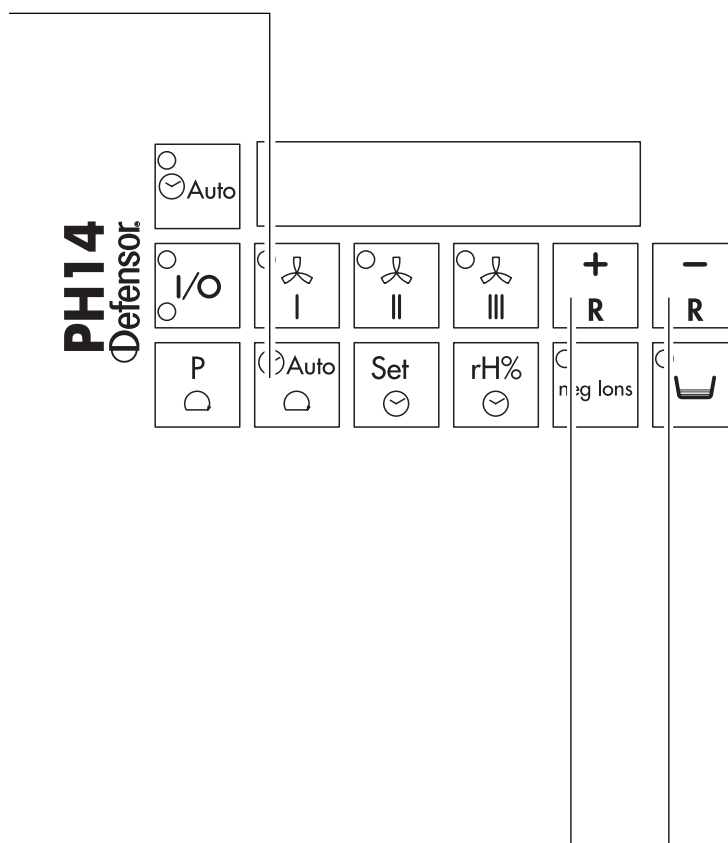

Costruzione, funzione, ubicazione

Costruzione

- 1 Griglia d'aspirazione
- 2 Filtro grossolano
- 3 Ventilatore
- 4 Centrifuga
- 5 Camera di lavaggio dell'aria
- 6 Evaporatore fioccosa o Evaporatore a carboni attivi
- 7 Separatore di gocce
- 8 Filtro per polvere grossa o Filtro Quattro
- 9 Serbatoi dell'acqua
- 10 Telaio mobile (con vasca dell'acqua PH14A)
- 11 Carrello dell'acqua

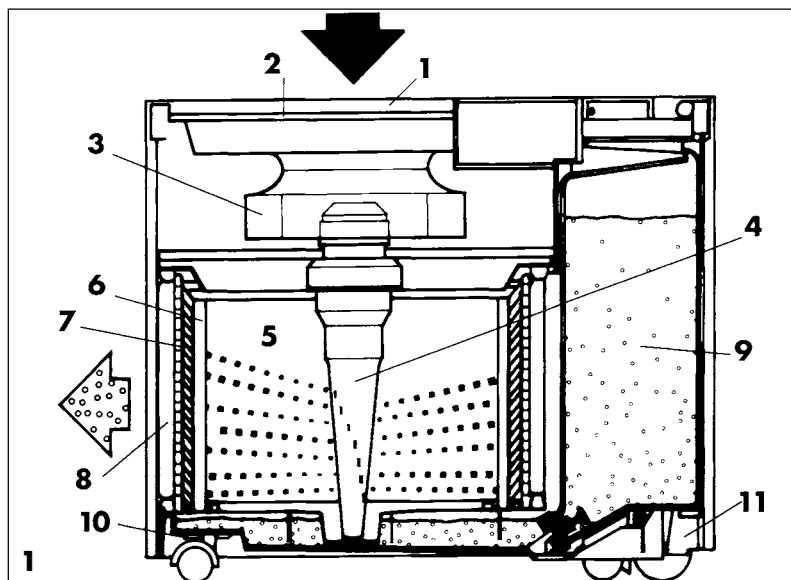

Funzione

L'apparecchio misura in continuità l'umidità del locale (valore effettivo) e lo compara con il valore impostato (valore nominale).

Il valore effettivo può divergere dal valore nominale. Quando il valore nominale non viene raggiunto per un periodo di tempo rilevante, allora si dovrà inserire lo stadio immediatamente più elevato dell'apparecchio.

Quando si desidera usare l'apparecchio per un lungo periodo di tempo, al solo scopo di purificare l'aria, deve essere svuotato il serbatoio dell'acqua, rispettivamente chiusa la valvola d'alimentazione dell'acqua (PH14A).

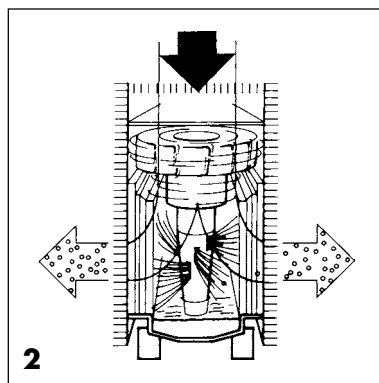

Quando il valore effettivo (per es. 40) è inferiore al valore nominale (per es. 45), l'apparecchio umidifica l'aria della stanza e contemporaneamente la purifica.

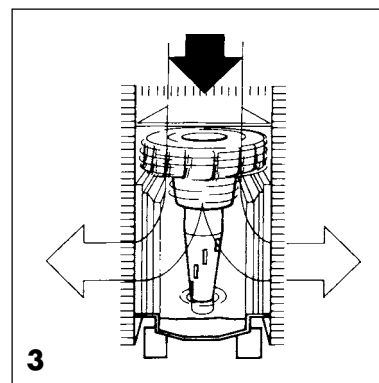

Quando viene raggiunto il valore regolato (per es. 45), l'apparecchio purifica l'aria dell'ambiente, senza umidificarla.

Scelta dell'ubicazione

Figuro 4 Si raggiunge una circolazione ottimale dell'aria dell'ambiente facendo attenzione a non piazzare l'apparecchio direttamente alla parete. Porre l'apparecchio su una superficie piana, possibilmente libero e ben raggiungibile.

Non collocare l'apparecchio dietro tende, perché la circolazione dell'aria ne soffrirebbe.

Collocando l'apparecchio sotto un tavolo, tra il tavolo e l'apparecchio deve esistere una luce netta di 10 cm. Non porre oggetti sull'apparecchio, ciò ne diminuirebbe il rendimento.

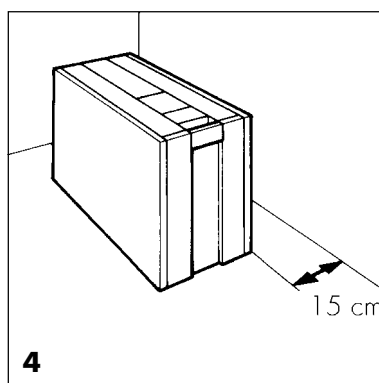

Fare attenzione spostando il PH14. Non sollevare l'apparecchio. (Esiste il pericolo che l'acqua trabocchi e versi sul pavimento.)

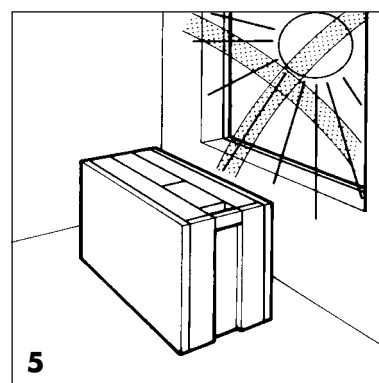

L'irradiazione diretta continua dei raggi del sole nuoce all'apparecchio.

Installazione/uso

Collegare l'acqua (PH14A)

Figura 1 L'apparecchio deve essere collegato da uno specialista (per i valori di collegamento, vedere i dati tecnici a pag. 45).

Prima dell'inserimento, controllare che la valvola d'alimentazione dell'acqua sia aperta.

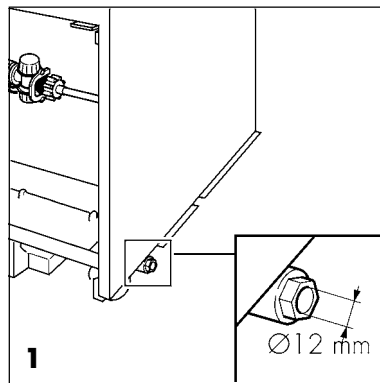

Controllare la tensione della rete

Figura 2 Controllare che la targhetta riporti la corretta tensione di rete.

Attenzione! Non collegare l'apparecchio, se questa indicazione non corrisponde alla tensione di rete del suo paese!

Bloccare le ruote

Figura 3 Quando l'apparecchio viene a trovarsi nel luogo desiderato, bloccare le ruote.

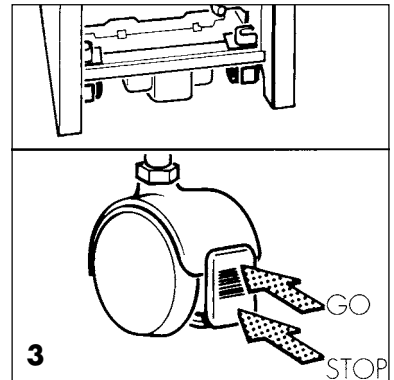
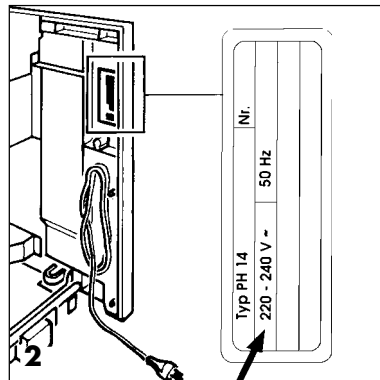

Riempire l'acqua (PH14)

Figura 4-7 Quando l'indicazione del valore nominale lampeggia e si accende la lampada "carenza d'acqua", i serbatoi sono vuoti. Prima di spostare il carrello dell'acqua, porre un panno sul pavimento per impedire che l'acqua goccioli su di esso.

Sollevare poi il manico e far scorrere via il carrello oppure, porre il carrello sul pavimento e prelevare i serbatoi.

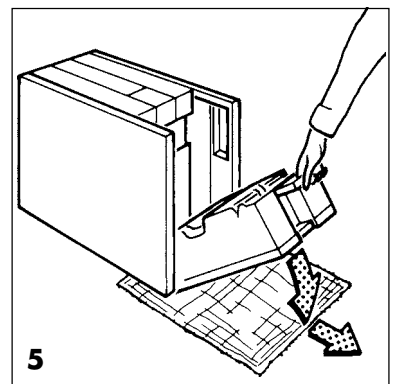
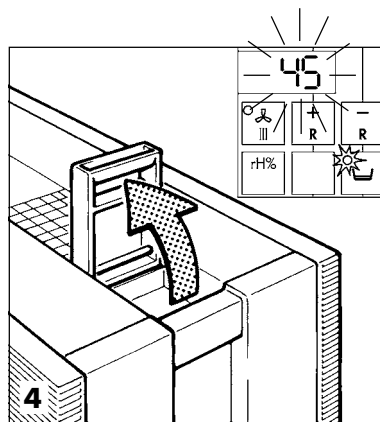

Riempire i serbatoi con acqua del rubinetto.

Attenzione! Gli additivi aggiunti all'acqua possono pregiudicare l'effetto detergente dell'evaporatore a carboni attivi.

Usare solo additivi per l'acqua che permettono di escludere danni alla salute, anche per quanto riguarda l'effetto a lungo termine. Osservare gli attestati di innocuità.

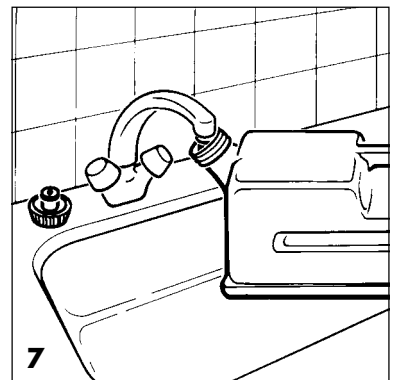
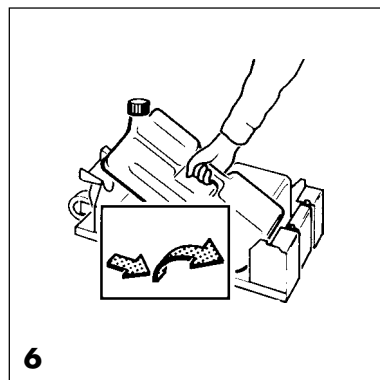

Uso

Inserire l'apparecchio

- Digitare il tasto ins/dis.
Poi, secondo le condizioni del locale, selettare gli stati di ventilatore I, II oppure III (vedere dati tecnici a pagina 45).
- Durante la **prima messa in esercizio**, digitare contemporaneamente i due tasti "R" per almeno 3 secondi (funzione Reset: vedere pagina 50).

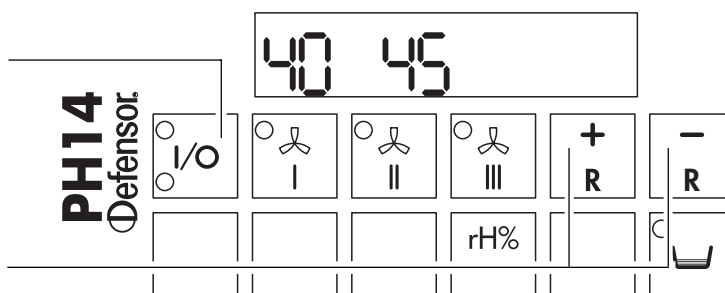

Selezionare il modo di esercizio

- **Purificazione e umidificazione**
Partire da fabbrica o dopo un Reset (vedere pagina 50) l'apparecchio marcia nel modo "Purificazione e umidificazione": Quando viene raggiunto l'umidità nominale la centrifuga ferma e il ventilatore continua marciare.

- **Umidificazione solo**

Premendo contemporaneamente i tasti di ventilatore "I" e "II" per almeno 3 secondi l'apparecchio commuta nel modo "Umidificazione solo": Quando viene raggiunto l'umidità nominale la centrifuga e il ventilatore fermano nello stesso tempo. Tutti i 15 minuti il ventilatore è attivato per 5 secondi per evitare l'accumulazione d'umidità nell'apparecchio.

Premendo contemporaneamente i tasti di ventilatore "II" e "III" per almeno 3 secondi, l'apparecchio ritorna nel modo "Purificazione e umidificazione".

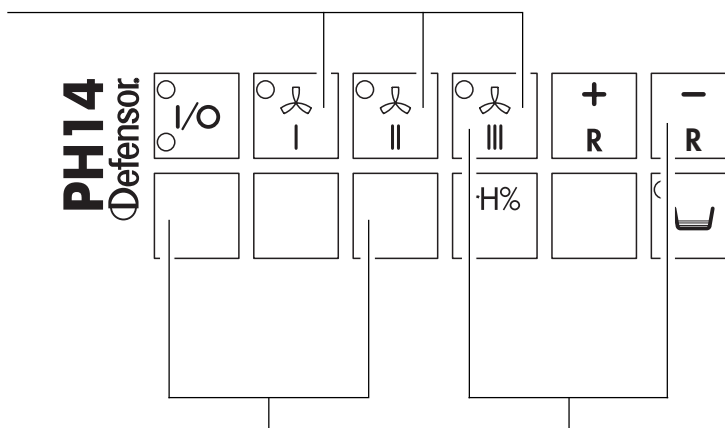

Desidera proteggere le regolazioni?

- Premere contemporaneamente per almeno 3 secondi questi due tasti.
Ora tutte le regolazioni sono protette (incl ins/dis).
Sbloccare la protezione procedendo come sopra.

Se il PH14 viene usato senza acqua, solo per purificare l'aria, l'indicazione di mancanza d'acqua lampeggia.

- Premendo contemporaneamente questi due tasti per almeno 3 secondi si può **disinserire l'indicazione di mancanza d'acqua**. Riempendo nuovamente con acqua, l'indicazione viene riattivata.

Letture dell'umidità ambiente

- Premere il tasto rH%.

Regolare il valore nominale

Per i locali d'abitazione consigliamo un'umidità relativa del 45%.

- Premere il tasto "più" o il tasto "meno", per aumentare o diminuire il valore regolato.

Se l'apparecchio è stato disattivato per un lungo periodo di tempo, l'esatta umidità del locale potrà essere letta solo dopo circa 30 minuti.

Togliendo il carrello dell'acqua, l'indicazione si disinserisce. Dopo il reinserimento, l'umidità esatta del locale potrà essere letta solo dopo circa 1 minuto.

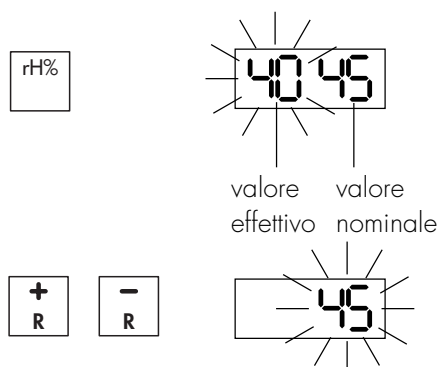

Manutenzione

L'apparecchio umidifica e purifica al massimo solo se viene pulito regolarmente e se i pezzi di usura vengono sostituiti. Pulire le parti esterne dell'apparecchio solo con un panno umido, senza usare detersivi abrasivi o corrosivi. Gli intervalli per la pulizia dipendono fortemente dal luogo d'impiego: se l'aria del locale è molto sporca, i filtri dovranno essere sostituiti più frequentemente. Se l'acqua è molto dura, le parti umide devono essere pulite più spesso.











- Pulire questi elementi:

Filtro grossolano – Filtro per polvere grossa o Filtro Quattro – Telaio mobile – Doppio fondo – Vasca dell'acqua – Separatore di gocce – Evaporatore fioccoso o Evaporatore a carboni attivi

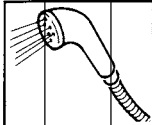
- Sostituire questi elementi:

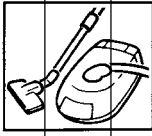
Filtro grossolano – Filtro per polvere grossa o Filtro Quattro – Evaporatore fioccoso o Evaporatore a carboni attivi

Mesi

1	2	3	4	5	6	7	8	9	10	11	12
											
											
											

Attenzione! Prima di cominciare con la manutenzione, staccare l'apparecchio dalla rete elettrica.

Figura 1 Sfilare prima la rete e mettere un panno sul pavimento, sotto il carrello dell'acqua.

Togliere il carrello dell'acqua.

Figura 2 Premere verso l'interno le due chiusure sotto all'apparecchio. Se l'apparecchio non viene spostato, le chiusure possono restare aperte (servono solo da sicurezza per il trasporto.)

Figura 3 Sollevare l'involucro.

Figura 4 Sollevare il filtro per polvere grossa o il filtro Quattro e il doppio fondo. Fare attenzione che filtro per polvere grossa o il filtro Quattro non si bagni.

Figura 5 PH14A: Svuotare la vasca dell'acqua con la pompa in dotazione.

Figura 6 Sollevare i due sostegni. Premere assieme l'evaporatore e estrarre.

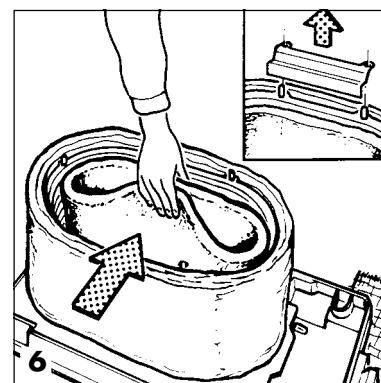
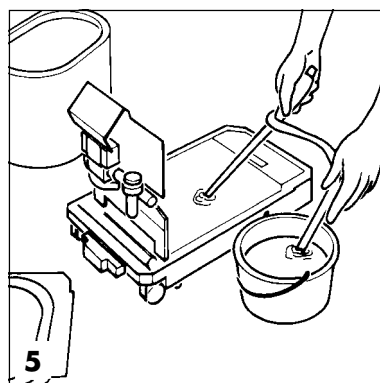
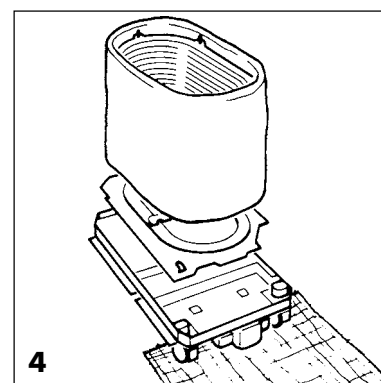
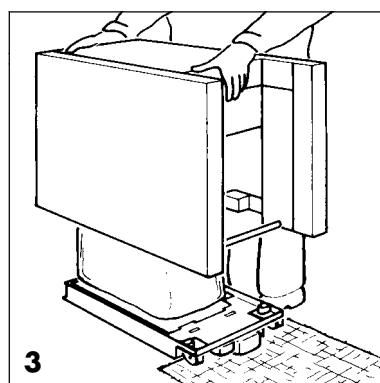
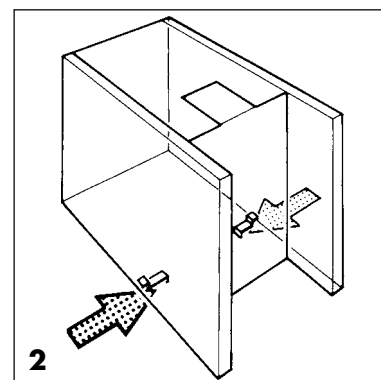
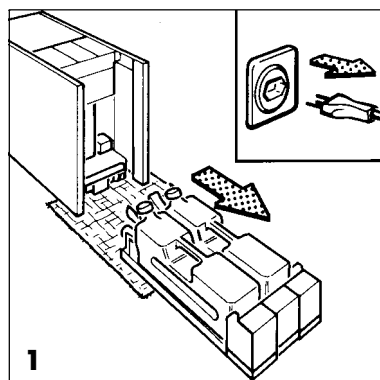

Manutenzione

Figura 1 Estrarre filtro per polvere grossa o il filtro Quattro.

Se lo sporco è poco, pulire con l'aspirapolvere.

Se è tanto, sostituire il filtro.

Figura 2 Ribaltare l'involucro.



Figura 3 Estrarre la centrifuga perpendicolarmente all'innesto.

Pulire l'interruttore a galleggiante.

(PH14A: anche l'interruttore di sicurezza).

Figura 4 Pulire la centrifuga servendosi della spazzola allegata.

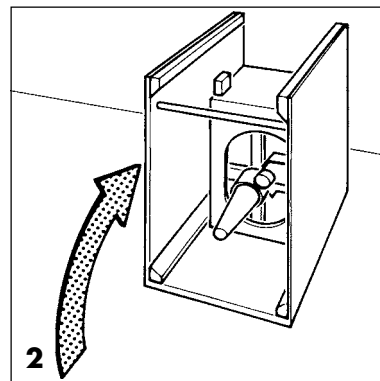
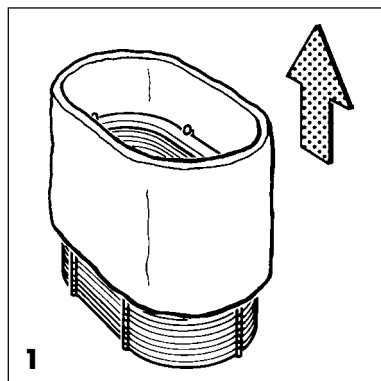
Nel inserire la centrifuga fare attenzione che agganci bene (altrimenti possono verificarsi vibrazioni).



Figura 5 PH14: Pulire l'evaporatore, il separatore di gocce, il doppio fondo e il telaio mobile.

Figura 6 PH14A: Pulire inoltre la vasca dell'acqua. Pulire l'evaporatore servendosi esclusivamente di acqua tiepida, senza detersivi. Di tanto in tanto, pulire le altre parti (figura 5 e 6) con un decalcificante o con aceto.

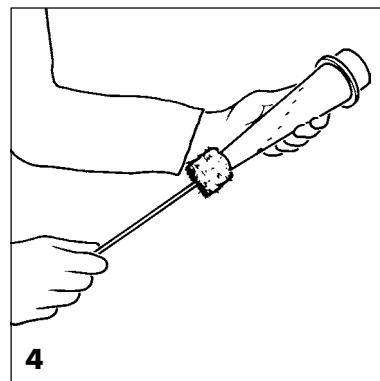
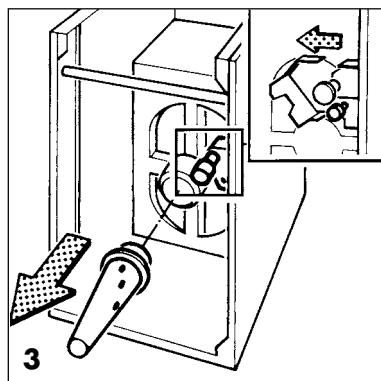

Figura 7 Pulire il filtro grossolano con un aspirapolvere, se è solo leggermente sporco.

Figura 8 Sostituirlo se è molto sporco.

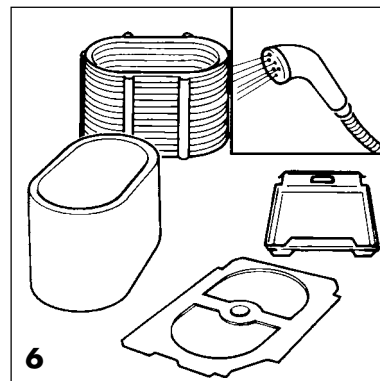
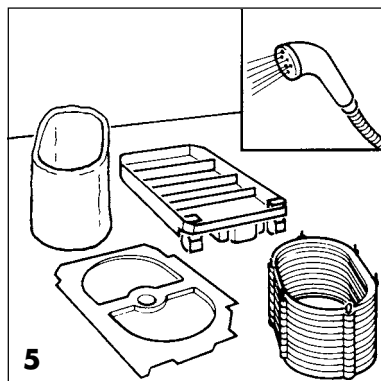
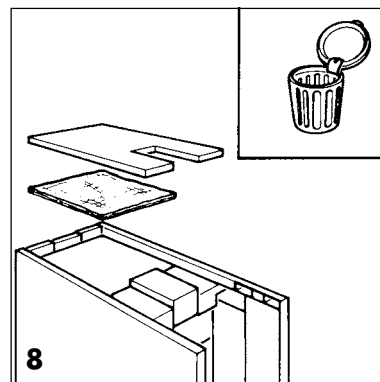
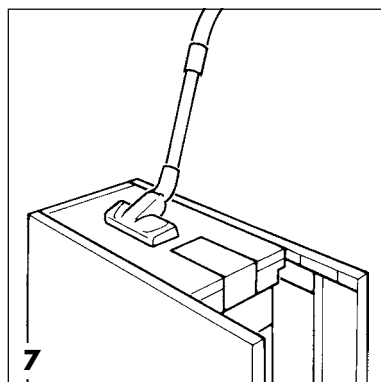

Manutenzione

Figura 1 PH14A: Avvitare la coppa di chiusura inferiore del filtro e lavare con acqua calda dal rubinetto.



Figura 2 Montando l'involucro dell'apparecchio fare attenzione che il coperchio dell'interruttore a galleggiante scorra accanto al filtro Quattro.



Figura 3 L'asta trasversale deve essere posta esattamente nel suo alloggiamento.

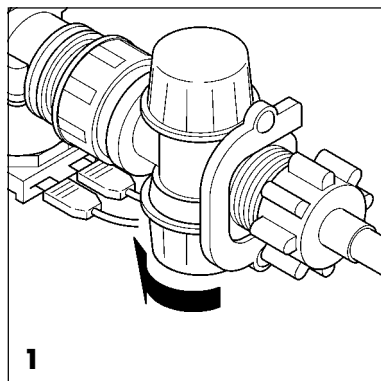

Attenzione! Lavare sempre a fondo sia l'apparecchio rimasto in disuso e dopo ogni decalcificazione.

Manutenzione supplementare per il PH14(A)plus

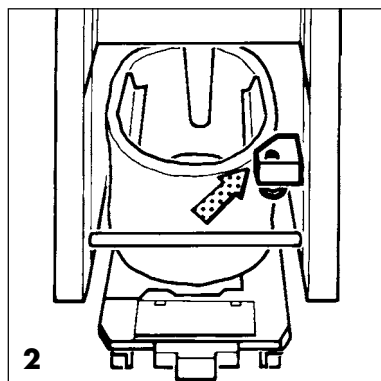
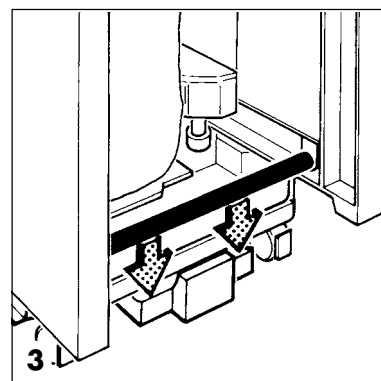
Durante ogni manutenzione dell'apparecchio, pulire l'ago d'ionizzazione servendosi di un piccolo panno. Dopo circa un anno, l'ago d'ionizzazione dovrebbe essere sostituito. L'ago d'ionizzazione può essere estratto con una pinzetta, che serve anche per inserire quello nuovo.

Dati tecnici

Dimensioni (LxAxP)	cm	73 x 61 x 37		
Peso (senz'acqua)	kg	25		
Contenuto serbatoi d'acqua	l	2 x 10		
Temperatura ambiente	°C	5 – 50		
Umidità ambiente	% u.r.	0 – 85		
Stadi di potenza		I	II	III
Circolazione dell'aria	m ³ /h	180	280	360
Potenza d'umidificazione (a 23 °C/45% u.r.)	l/h	0.6	0.9	1.2
Livello sonoro (DIN45635)	dB(A)	41	49	56
Superficie filtrante	m ²	0.4		
Rendimento contro la polvere atmosferica	%	82		
Grado di separazione di filtro Quattro contro la polvere sintetica %		>99		
Tensione di rete	V ~	100... 120/220...240		
Frequenza di rete	Hz	50/60		
Assorbimento di potenza	W	mass. 55		
Contrassegni di sicurezza		SEV, VDE, GS, CE		
PH14A:				
Colleg. dell'acqua (Ø esterna)	mm	12		
Pressione della rete idrica	bar	0.5 – 6		
Temperatura dell'adduzione d'acqua	°C	5 – 40		
PH14(A)plus:				
Ioni negativi	ioni neg./cm ³	300 – 600'000		
Tensione d'uscita dell'ionizzatore	kV (neg.)	6.5		



Grandezza massima del locale

Stadio di potenza	Dimensione del locale per la umidificazione dell'aria (con una richiesta d'umidità di 2,5 g/h·m ³)	Dimensione del locale per la purificazione dell'aria (con una circolazione d'aria semplice fino a quadrupla all'ora)
I	max. 180 m ³	max. 45 m ³ bis 180 m ³
II	max. 280 m ³	max. 70 m ³ bis 280 m ³
III	max. 360 m ³	max. 90 m ³ bis 360 m ³

Esempio 1: Si desidera purificare l'aria di un locale con una superficie di 80 m² e alto 2,5 m.
80 m² x 2,5 m = 200 m³
In dipendenza dell'umidità dell'aria naturale, l'aria di questo locale può essere umidificata con il PH 14 funzionante agli stadi I fino a II.

Esempio 2: Si desidera umidificare l'aria di un locale con una superficie di 110 m² e alto 3,2 m.
110 m² x 3,2 m = 352 m³
Con un PH14 inserito allo stadio III, l'aria di questo locale circola 1 volta all'ora.

Cosa fare se?

Guasto	Causa	Eliminazione
 Solo PH14A: La lampada rossa del tasto vasca 1/0 è accesa, l'indicazione "Help" lampeggia	Il livello dell'acqua nella vasca è eccessivo	<ul style="list-style-type: none"> • Svuotare la vasca dell'acqua con una pompa • Pulire l'interruttore di sicurezza o sostituirlo • Avvertire il distributore Defensor
 La lampada gialla è accesa e il valore nominale lampeggia	Il telaio mobile, rispettiv. La vasca dell'acqua sono senz'acqua	PH14: <ul style="list-style-type: none"> • Rabboccare il serbatoio dell'acqua • Controllare l'alimentazione dell'acqua • Pulire l'interruttore a galleggiante PH14A: • Pulire la cartuccia del filtro o sostituirla • Pulire l'interruttore a galleggiante • Avvertire il distributore Defensor
L'aria del locale non raggiunge l'umidità regolata (valore nominale)	<ul style="list-style-type: none"> – Manca l'evaporatore – Elevata temperatura dell'aria. – L'apparecchio è molto sporco. – Porte e finestre aperte. – Frequente e lunga ventilazione del locale (quindi continuo ricambio dell'aria dell'ambiente umida con l'aria esterna secca). – Il locale è troppo grande 	<ul style="list-style-type: none"> • Inserire un nuovo evaporatore • Ridurre la temperatura dell'aria a 20 – 22°C. • Eseguire la manutenz. (p. 42–44) • Chiudere porte e finestre • Ventilare solo brevemente! (l'apparecchio pulisce l'aria dell'ambiente) • Occorrono più apparecchi
Le indicazioni non si accendono	La maniglia non è correttamente agganciata La spina di rete non è inserita	<ul style="list-style-type: none"> • Agganciare la maniglia • Controllare il collegamento alla spina di rete • Controllare il fusibile di rete di questo locale
Il valore nominale viene chiaramente superato	L'umidità naturale dell'aria è superiore al valore regolato (valore nominale).	L'apparecchio può continuare a funzionare per pulire l'aria del locale
Dopo il riempimento dei serbatoi dell'acqua oppure dopo aver sfilato la spina dalla rete oppure dopo una interruzione di corrente, l'apparecchio non commuta allo stadio di ventilazione impostato in precedenza	La batteria tampone è scarica.	Far sostituire la batteria da un distributore Defensor

Garanzia: Prima di uscire dalla fabbrica, il suo purificatore-umidificatore PH14 è stato sottoposto ad un accurato esame. La garanzia è valida per 1 anno dalla data della fattura. Durante questo periodo verranno sostituiti gratuitamente tutti i pezzi difettosi a causa di errori di materiale e di fabbricazione. Dalla garanzia sono esclusi:

- I danni causati da un trattamento o da interventi inappropriati.
- Le parti soggette ad usura, che a causa della loro funzione sono esposte ad un consumo naturale.

Per l'eventuale spedizione dell'apparecchio difettoso, usare l'imballaggio originale. Esso offre una protezione ottimale per il trasporto.

Attenzione! Il cavo di collegamento alla rete può essere sostituito solo dall'elettricista specializzato o da un distributore Defensor autorizzato.

Regolazione del timer/ionizzazione

Inserire l'ionizzazione

Mediante l'inserimento del generatore di ioni negativi, l'aria dell'ambiente viene liberata anche dalle particelle di polvere più piccole che possono nuocere alla salute, quali il fumo di tabacco e la fuliggine.

Gli ioni negativi attirano le particelle di polvere sospese e si collegano con altre particelle di polvere, formando i cosiddetti cluster i quali, grazie alla loro grandezza, vengono trattenuti efficacemente dal filtro d'aria. L'ionizzazione dell'aria fa inoltre diminuire il pericolo delle cariche elettrostatiche.



Attenzione! La parte più grande dei cluster di polvere formati grazie all'ionizzazione inserita viene trattenuta nel filtro d'aria. Però è possibile, specialmente quando l'aria del locale è particolarmente sporca, che una piccola parte dei cluster di polvere si posino sulle pareti o su altre superfici del locale. Non collocare il PH14 plus nelle immediate vicinanze di una parete o di una tenda. Decliniamo ogni responsabilità per l'eventuale deposito di polvere sulle superfici.

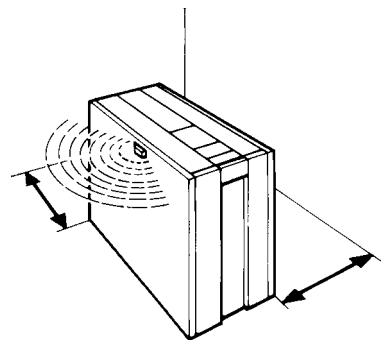

Regolazione del timer

Controllare l'ora

- Premere il tasto "Set".

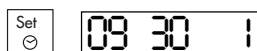

Appare l'ora regolata e il giorno della settimana regolato (lunedì = 1 ... domenica = 7).

Regolare l'ora

- Premere contemporaneamente il tasto "Set" ed il tasto "rH%".

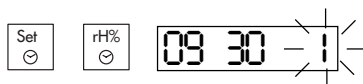

Ora si può regolare l'ora e il giorno della settimana.

Esempio:

Il suo apparecchio mostra le ore 9 e 30, lunedì (=1).

Effettivamente sono invece le ore 14 e 10, mercoledì (=3).

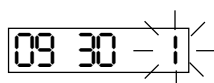

Iniziare regolando il giorno della settimana.

- Digitare il tasto "+" fino a quando appare il "3".
- Digitare il tasto "Set" e regolare le ore.
- Digitare il tasto "Set" e regolare i minuti.
- Digitare nuovamente il tasto "Set".

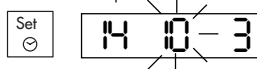
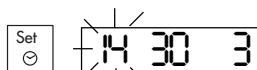
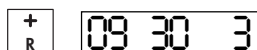

Dopo circa 10 secondi, l'apparecchio indica nuovamente il valore nominale dell'umidità dell'aria del locale.

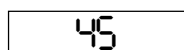

Regolazione del timer

Funzione

Per ogni giorno della settimana sono a disposizione un massimo di 4 orari d'inserimento.

Per ogni orario d'inserimento si possono eseguire le seguenti regolazioni:

- Giorno della settimana (1-7= lu-do)
- Ora (0-24)
- Minuti (0-60)
- Stadio ventilazione (I/II/III)
- Senza inserire stadi di ventilazione (disinserire)

Le regolazioni determinano sempre lo stato d'esercizio fino al prossimo orario d'inserimento.

Nell'esempio, l'apparecchio inserisce il giovedì, alle ore 13, lo stadio 1. Anche il giorno seguente, l'apparecchio funziona allo stesso stadio e solo il primo stadio d'inserimento del mercoledì, ore 12, l'apparecchio commuta allo stadio 3.

Esempio:

Lunedì

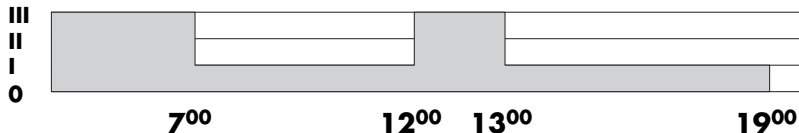

Martedì

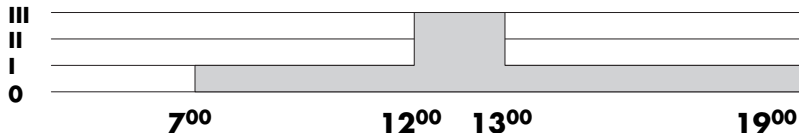

Mercoledì

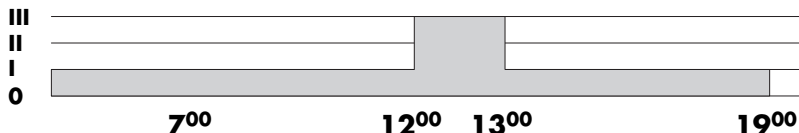

Giovedì

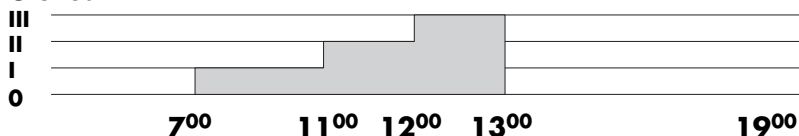

Venerdì

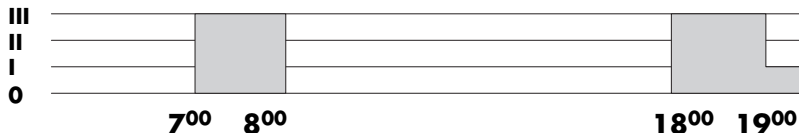

Sabato

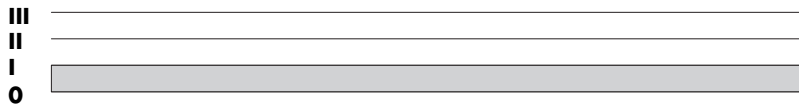

Domenica

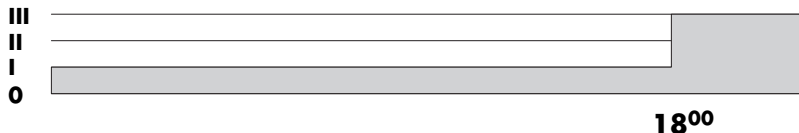

Regolare gli orari d'inserimento per martedì e mercoledì (vedere l'esempio). Procedere come segue:

- Premere per 3 secondi il tasto "P". L'indicazione giornaliera lampeggia. Ora è possibile regolare gli orari d'inserimento.
- Regolare il giorno servendosi dei tasti "+/-" (nell'esempio: martedì=2).
- Digitare "Set" e regolare le ore (nell'esempio: 07).
- Digitare "Set" e regolare i minuti (nell'esempio: 00).
- Digitare "Set" e scegliere lo stadio di ventilazione. Digitare il rispettivo tasto di ventilazione (nell'esempio stadio 1).

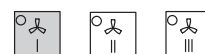
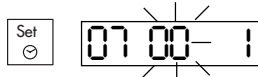
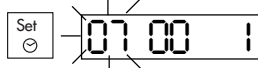
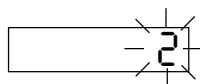
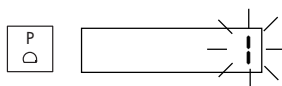

Regolazione del timer

- Digitare "Set". Ora è possibile regolare gli altri orari d'inserimento del martedì.



2° Orario d'inserimento di martedì.

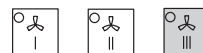
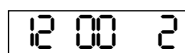

3° Orario d'inserimento di martedì.

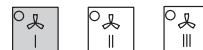
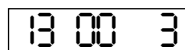

Non occorrendo un 4° orario d'inserimento, premere semplicemente più volte "Set", fino a quando viene indicata l'ora. Dopo 10 secondi appare il valore nominale dell'umidità dell'aria. Con ciò la regolazione degli orari d'inserimento per martedì è terminata.



Regolare ora gli orari d'inserimento per mercoledì. Premere nuovamente per 3 secondi il tasto "P" e regolare il "3" per il giorno della settimana. Procedere poi allo stesso modo di prima:

1° Orario d'inserimento mercoledì

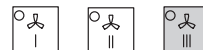
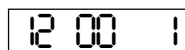

2° Orario d'inserimento mercoledì

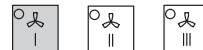
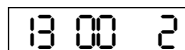

3° Orario d'inserimento mercoledì

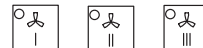
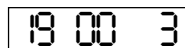

Affinché l'apparecchio disinserisca alle ore 19.00, non selettare nessun stadio di ventilazione, ma premere subito "Set".

Digitare nuovamente più volte "Set", fino a quando viene indicata l'ora, rispettivamente dopo 10 secondi l'umidità dell'aria. Ora è stato regolato l'orario d'inserimento per mercoledì.

Richiedere gli orari d'inserimento

- Premere contemporaneamente i tasti "P" e il tasto "Auto". L'indicazione giornaliera lampeggia.

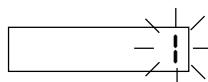

Con i tasti "+/-", selettare il giorno (nell'esempio martedì=2).

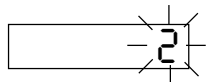

- Premere "Set". Ora si vede il primo (di quattro) orario d'inserimento del giorno selettato e lo stadio di ventilazione regolato.

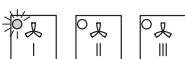

- Premere "Set" per il secondo, il terzo e il quarto orario d'inserimento.



- Premere nuovamente "Set".



Adesso l'apparecchio indica nuovamente l'orario e dopo 10 secondi il valore nominale dell'umidità dell'aria. Ripetere la richiesta per gli altri giorni della settimana.

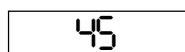

Regolazione del timer

Timer automatico ins/dis

Digitare il tasto "Auto" per inserire o disinserire il dispositivo automatico del timer.

Quando l'automatico è in funzione, si può continuare ad usare normalmente l'apparecchio.

Gli stadi di ventilazione possono essere cambiati liberamente e l'apparecchio può anche essere inserito e disinserito.

Può accadere che l'apparecchio non reagisca alla pressione di un tasto, perchè l'automatico del timer è in funzione. Ripetere la prova dopo ca. 2 minuti.

Dopo il prossimo orario d'inserimento, l'automatico del timer rirregola il valore che ha determinato durante la regolazione dell'orario d'inserimento.

Reset

Premendo i due tasti "R" è possibile azzerare tutti gli orari d'inserimento e l'ora dell'orologio.

Contemporaneamente, il valore nominale dell'umidità dell'aria viene posto a 45%.

In caso di un'eventuale funzione errata del comando dell'apparecchio, può servire premere il tasto reset.

La funzione reset non è in esercizio dopo che le regolazioni sono state protette (vedere "proteggere le regolazioni").

Proteggere le regolazioni

Gli orari d'inserimento regolati possono essere protetti contro le modifiche involontarie (vedere a pagina 41).

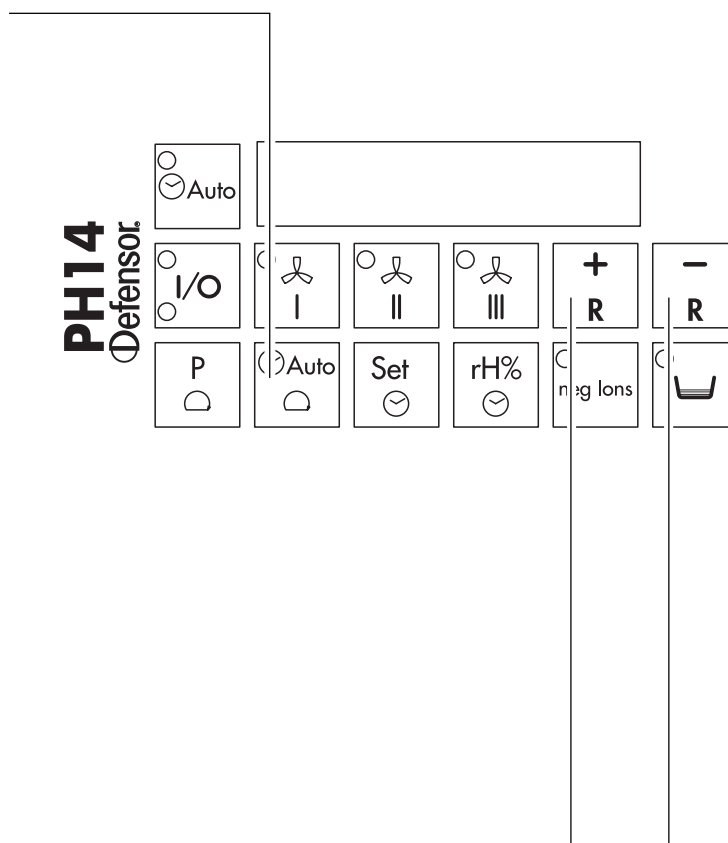

Ersatzteile/Spare parts/Pièces de rechange/Ricambi

PH14 / PH14 plus

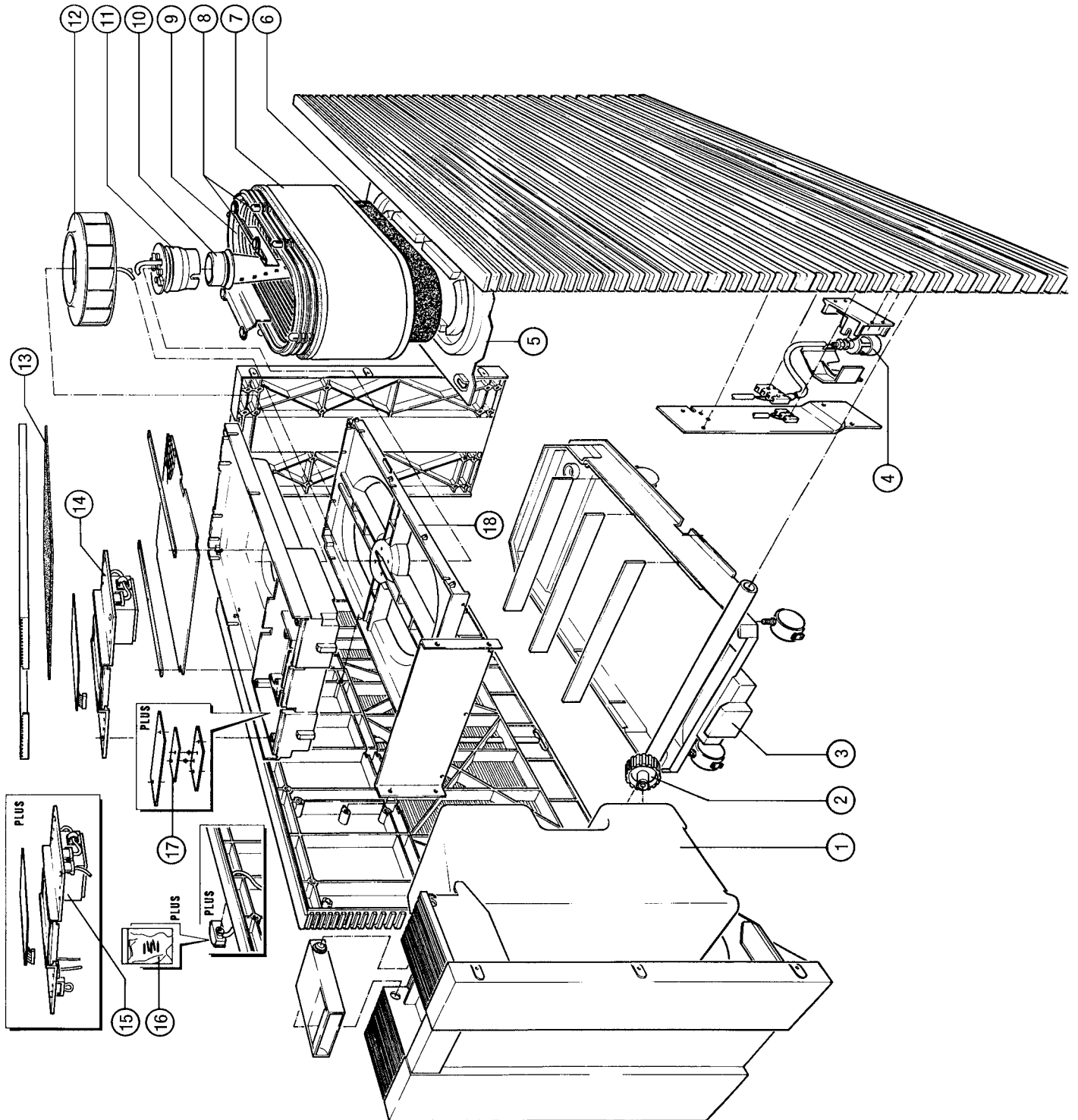

Ersatzteile/Spare parts/Pièces de rechange/Ricambi

Pos.	Art. No.	Ersatzteile	Spare Parts	Pièces de rechange	Ricambi
1	1104570	Wassertank	Water tank	Réservoir d'eau	Serbatoio d'acqua
2	1104450	Niveauregulierventil	level regulating valve	Vanne de réglage à niveau	Valvola di regolazione del livello
3	1103175	Fahrgestell kpl., Tankversion	Mobile base cpl.	Chassis mobile cpl.	Carellino mobile compl.
4	1104462	Niveauschalter kpl.	level switch cpl.	Commutateur à niveau cpl.	Interruttore livello compl.
5	1103179	Wannendeckel	Base cover	Couvercle de chassis	Coperchio del carellino
6	1110398	Aktivkohle-Befeuchtermatte	Activated carbon evaporator mat	Natte d'évaporation à charbon	Evaporatore a carboni attivi
	1100465	Befeuchtermatte, beflocht	Evaporator mat, flock-coated	Natte d'évaporation, floconnoux	Evaporatore fioccosa
7	1101225	Grobstaubfilter	Coarse dust filter	Filtre à poussière grossier	Filtro per polvere grossa
	1110259	Quattro-Filter	Quattro filter	Filtre Quattro	Filtro Quattro
8	1102685	Verbindungsstangen mit Halter	Connecting bars with support	Barres de jonction avec support	Bastoni di connes. con sostegno
9	1104457	Tropfenabscheider	Droplet trap	Élément séparateur	Separatore di gocce
10	1104467	Kreisel	Impeller	Pompe centrifuge	Centrifuga
11	1103190	Kreiselantrieb	Impeller motor	Moteur pour pompe centrifuge	Motore della centrifuga
12	1103187	Ventilator	Fan	Ventilateur	Ventilatore
13	1102319	Grobfilter (5 Stk.)	Coarse filter (5 pcs.)	Filtre grossier (5 pcs.)	Filtro grossolano (5 pezzi)
14	1112088	Steuerprint kpl. 200...240V/50Hz	Control PCB cpl.	Carte de commande cpl.	Scheda di comando compl.
	1111899	Steuerprint kpl. 100...120V/50Hz	Control PCB cpl.	Carte de commande cpl.	Scheda di comando compl.
	1113809	Steuerprint kpl. 100...120V/60Hz	Control PCB cpl.	Carte de commande cpl.	Scheda di comando compl.
15	1112092	Steuerprint "Plus" kpl. 200...240V/50Hz	Control "Plus" PCB cpl.	Carte de commande "Plus" cpl.	Scheda di comando "plus" compl.
	1113810	Steuerprint "Plus" kpl. 100...120V/50Hz	Control "Plus" PCB cpl.	Carte de commande "Plus" cpl.	Scheda di comando "plus" compl.
	1113811	Steuerprint "Plus" kpl. 100...120V/60Hz	Control "Plus" PCB cpl.	Carte de commande "Plus" cpl.	Scheda di comando "plus" compl.
16	1102984	Ionisiermadel-Set	Ionization needle set	Set d'aiguille de ionisation	Set ago d'ionizzazione
17	1112407	Print Luftionisierung	Ionization PCB	Carte de ionisation	Scheda ionizzazione d'aria
18	1103777	Motorträger kpl.	Motor support cpl.	Support du moteur cpl.	Supporto motore compl.

Ersatzteile/Spare parts/Pièces de rechange/Ricambi

PH14A / PH14A plus

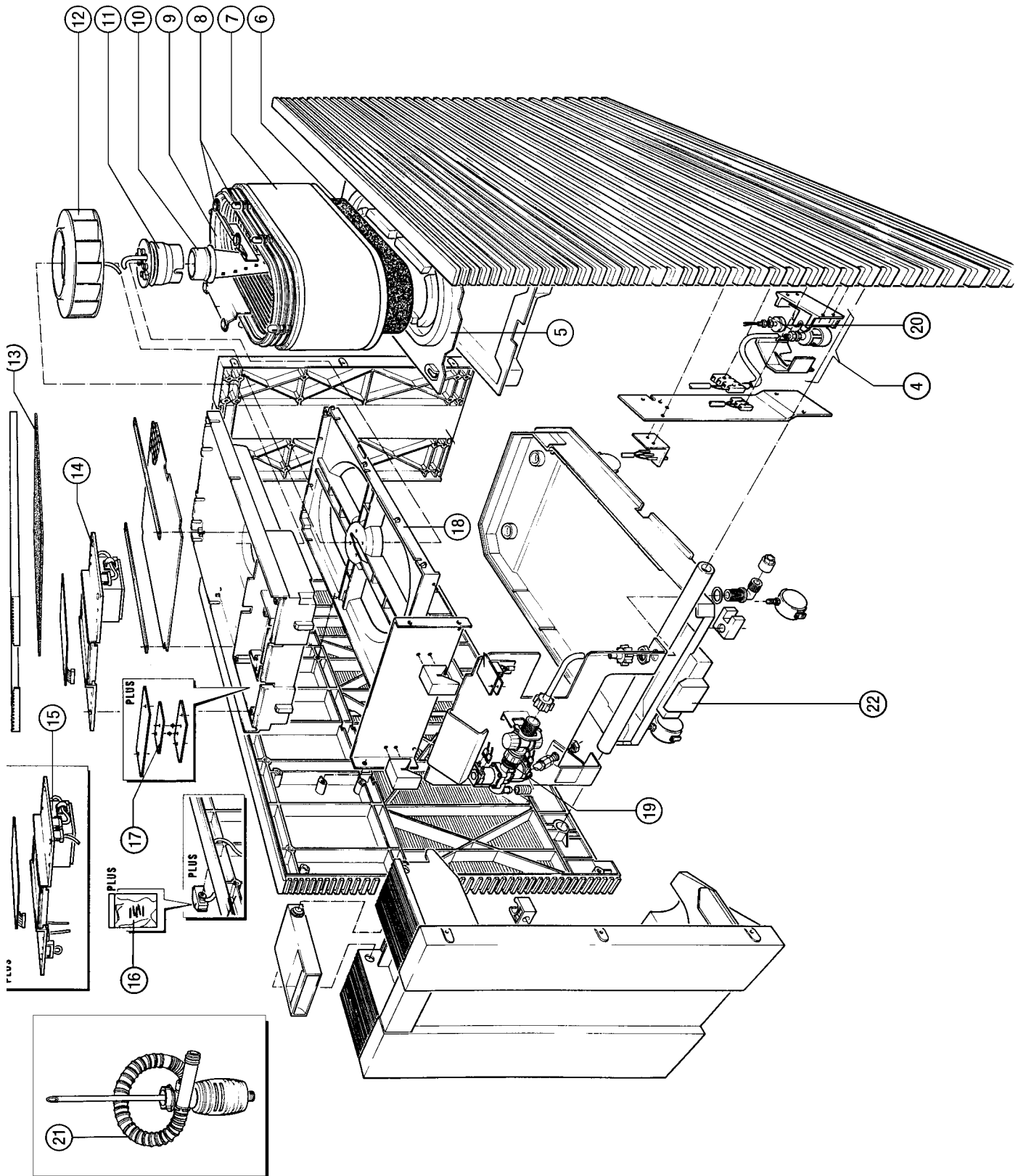

Ersatzteile/Spare parts/Pièces de rechange/Ricambi

Pos.	Art. No.	Ersatzteile	Spare Parts	Pièces de rechange	Ricambi
4	1104462	Niveauschalter kpl.	Level switch cpl.	Commutateur à niveau cpl.	Interruttore livello compl.
5	1103179	Wannendeckel	Base cover	Couvercle de chassis	Coperchio del carello
6	1110398	Aktivkohle-Befeuchtermatte	Activated carbon evaporator mat	Natte d'évaporation à charbon	Evaporatore a carboni attivi
	1100465	Befeuchtermatte, beflocht	Evaporator mat, flock-coated	Natte d'évaporation, floconnoux	Evaporatore fioccosa
7	1101225	Grobstaubfilter	Coarse dust filter	Filtere à poussière grossier	Filtro per polvere grossa
	1110259	Quattro-Filter	Quattro filter	Filtere Quattro	Filtro Quattro
8	1102685	Verbindungsstangen mit Halter	Connecting bars with support	Barres de jonction avec support	Bastoni di connes. con sostegno
9	1104457	Tropfenabscheider	Droplet trap	Élément séparateur	Separatore di gocce
10	1104467	Kreisel	Impeller	Pompe centrifuge	Centrifuga
11	1103190	Kreiselantrieb	Impeller motor	Moteur pour pompe centrifuge	Motore della centrifuga
12	1103187	Ventilator	Fan	Ventilateur	Ventilatore
13	1102319	Grobfilter (5 Stk.)	Coarse filter (5 pcs.)	Filtere grossier (5 pcs.)	Filtro grossolano (5 pezzi)
14	1112088	Steuerprint kpl. 200...240V/50Hz	Control PCB cpl.	Carte de commande cpl.	Scheda di comando compl.
	1111899	Steuerprint kpl. 100...120V/50Hz	Control PCB cpl.	Carte de commande cpl.	Scheda di comando compl.
	1113809	Steuerprint kpl. 100...120V/60Hz	Control PCB cpl.	Carte de commande cpl.	Scheda di comando compl.
15	1112092	Steuerprint "Plus" kpl. 200...240V/50Hz	Control "Plus" PCB cpl.	Carte de commande "Plus" cpl.	Scheda di comando "plus" compl.
	1113810	Steuerprint "Plus" kpl. 100...120V/50Hz	Control "Plus" PCB cpl.	Carte de commande "Plus" cpl.	Scheda di comando "plus" compl.
	1113811	Steuerprint "Plus" kpl. 100...120V/60Hz	Control "Plus" PCB cpl.	Carte de commande "Plus" cpl.	Scheda di comando "plus" compl.
16	1102984	Ionisiermodel-Set	Ionization needle set	Set d'aiguille de ionisation	Set ago d'ionizzazione
17	1112407	Print Luftionisierung	Ionization PCB	Carte de ionisation	Scheda ionizzazione d'aria
18	1103777	Motorträger kpl.	Motor support cpl.	Support du moteur cpl.	Supporto motore compl.
19	1100311	Einlassventil kpl.	Inlet valve cpl.	Vanne d'admission cpl.	Valvola di presa compl.
20	1103785	Sicherheitsschalter-Set	Level safety switch	Commutateur de sécurité	Set interruttore di sicurezza
21	1103790	Handpumpe	hand pump	Pompe à main	Pompa a mano
22	1103196	Fahrgestell kpl., PH14A/PH14A plus	Mobile base cpl.	Chassis mobile cpl.	Carello mobile compl.



Reg.No. 40002-2

Consulting, Sales and Service:

Manufacturer:

Axair Ltd. Systems for Air Treatment

A WMH Company

CH-8808 Pfäffikon (Switzerland), Talstr. 35-37, P.O. Box

Telephone +41 55 416 61 11, Fax +41 55 416 62 62

Internet <http://www.axair.ch>, E-Mail info@axair.ch

Defensor[®]